

R-Type® Reversing Secondary Cleaner

KEY FEATURES AND BENEFITS

- 1. A reversing secondary cleaner.** The R-Type® can be positioned in any secondary location from 4" (100mm) off the head pulley to anywhere down the beltline. It is designed for use on reversing and shuttling conveyors, and conveyors that roll back such as trippers or stackers.
- 2. Constant, controlled blade pressure.** Each 6" (150mm) tip is independently tensioned by its own cushion to maintain a more consistent blade-to-belt pressure, reduce blade re-tensioning maintenance and ensure high cleaning efficiency throughout the life of the blade.
- 3. High cleaning efficiency.** The C-Tip is made of an impact-resistant tungsten carbide, and the individual cushions are designed to keep the tip at a 90° angle to the belt. The result: maximum cleaning power.
- 4. Works with mechanical fasteners.** The C-Tip can be used with mechanical splices. The shock-absorbing cushion allows the splice to easily pass without damage to the tip or to the splice and with minimal cleaning disruption. Countersinking (skiving) the splice is always a benefit to both cleaning efficiency and blade and splice wear.
- 5. Self-cleaning.** The cleaner has minimal horizontal surfaces for carryback to build up on. This type of carryback buildup often renders other secondary cleaners ineffective.

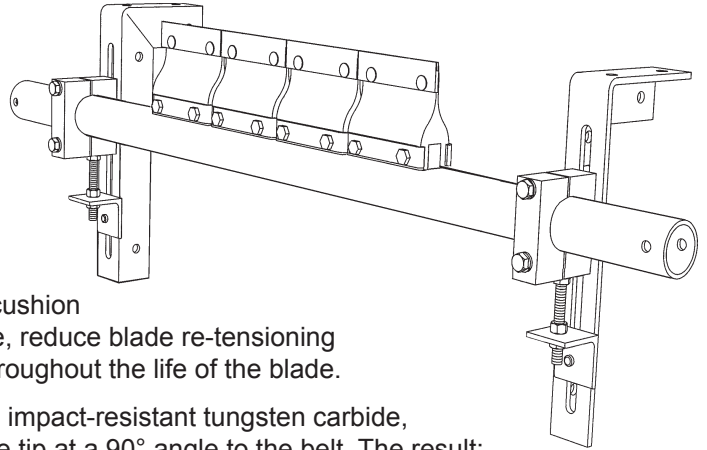

OTHER FEATURES AND BENEFITS

- 6. Easy to install.** The cleaner is shipped ready to install. It can be bolted or welded to the conveyor structure. And each cleaner comes with laminated installation instructions with simple step-by-step directions.
- 7. Simple to tension.** Turn the adjusting nuts on each side of the cleaner to quickly and easily tension the cleaner.
- 8. Minimal maintenance.** Typical preventive maintenance is a quick visual inspection of the cleaner as it is running. Cleaner adjustment is recommended every 8 to 12 weeks as the blades wear in.
- 9. Compact design.** The R-Type requires only 8" (200mm) of vertical clearance for correct installation. It will fit in most tight chute or conveyor structure situations.
- 10. Complete cleaning system.** When teamed with the H-Type® Precleaner as a system it delivers the highest cleaning efficiency available for reversing belts.
- 11. Service and support.** Flexco has a variety of support options for specifying, installing or servicing your belt cleaners, including: local distributor service, on-site training, factory technical support and a 24-hour BCP Help Line.
- 12. Our "Performance Guarantee".** If after 30 days, we can't make your Eliminator Belt Cleaner perform to your satisfaction you can return it for a full credit or refund.