

# Product Ordering Information

Eliminator® U-Type®  
Secondary Cleaner

## U-Type® with V-Blade (Tungsten Carbide)\*

CLEANER COMPLETE				REPLACEMENT V-BLADE			
BELT WIDTH		ORDERING NUMBER	ITEM CODE	WT. LBS.	ORDERING NUMBER	ITEM CODE	WT. LBS.
in.	mm						
18	450	UTV18	76700	84.4	URVB18	76736	7.0
24	600	UTV24	76701	90.8	URVB24	76737	8.5
30	750	UTV30	76702	96.6	URVB30	76738	10.0
36	900	UTV36	76703	102.4	URVB36	76739	11.5
42	1050	UTV42	76704	108.0	URVB42	76740	13.5
48	1200	UTV48	76705	114.1	URVB48	76741	15.0
54	1350	UTV54	76706	119.5	URVB54	76742	16.5
60	1500	UTV60	76707	125.4	URVB60	76743	18.0
72	1800	UTV72	76708	157.5	URVB72	76744	19.5
84	2100	UTV84	76709	172.4	URVB84	76745	22.7

\*NOTE: V-Blades (Tungsten Carbide) can be used on vulcanized belts and mechanically spliced belts ONLY IF the splice is skived (recessed into the belt's cover) (on solid plate splices the bolts must be ground).

CAUTION: The V-Blade CANNOT be used on belts with mechanical rip repair fasteners. Use the F-Blade.

Lead time: 1 working day

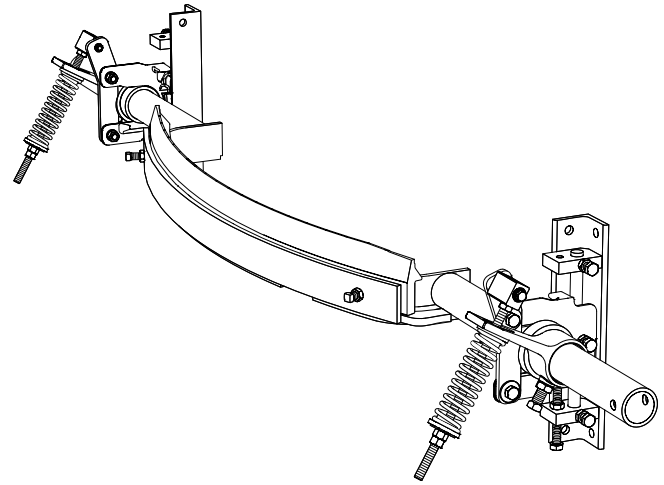

## U-Type® with C-Blade (Impact-Resistant Tungsten Carbide)\*

CLEANER COMPLETE				REPLACEMENT C-BLADE			
BELT WIDTH		ORDERING NUMBER	ITEM CODE	WT. LBS.	ORDERING NUMBER	ITEM CODE	WT. LBS.
in.	mm						
18	450	UTC18	76712	84.4	URCB18	76748	5.5
24	600	UTC24	76713	90.8	URCB24	76749	7.6
30	750	UTC30	76714	96.6	URCB30	76750	9.8
36	900	UTC36	76715	102.4	URCB36	76751	12.0
42	1050	UTC42	76716	108.0	URCB42	76752	14.2
48	1200	UTC48	76717	114.1	URCB48	76753	16.5
54	1350	UTC54	76718	119.5	URCB54	76754	18.8
60	1500	UTC60	76719	125.4	URCB60	76755	21.0
72	1800	UTC72	76720	157.5	URCB72	76756	23.2
84	2100	UTC84	76721	172.4	URCB84	76757	25.4

\*NOTE: C-Blades can be used on Flexco® Solid Plate, mechanically fastened and vulcanized belts.

Lead time: 1 working day

## U-Type® with F-Blade (Urethane)\*

CLEANER COMPLETE				REPLACEMENT F-BLADE			
BELT WIDTH		ORDERING NUMBER	ITEM CODE	WT. LBS.	ORDERING NUMBER	ITEM CODE	WT. LBS.
in.	mm						
18	450	UTF18	76724	84.4	UFB18	74448	3.0
24	600	UTF24	76725	90.8	UFB24	74449	4.0
30	750	UTF30	76726	96.6	UFB30	74450	5.0
36	900	UTF36	76727	102.4	UFB36	74451	6.0
42	1050	UTF42	76728	108.0	UFB42	74452	7.0
48	1200	UTF48	76729	114.1	UFB48	74453	7.5
54	1350	UTF54	76730	119.5	UFB54	74454	8.5
60	1500	UTF60	76731	125.4	UFB60	74455	9.5
72	1800	UTF72	76732	157.5	UFB72	74456	11.0
84	2100	UTF84	76733	172.4	UFB84	74460	12.8

\*NOTE: F-Blades (Urethane) can be used on mechanically spliced belts and vulcanized belts.

Lead time: 1 working day

**Eliminator®**  
BELT CLEANING SYSTEMS