

# Product Ordering Information

*Eliminator® Chevron  
Belt Cleaner*

## Chevron Belt Cleaner

BELT WIDTH		DRUM WIDTH		ORDERING NUMBER	ITEM CODE	WT. LBS.
in.	mm	in.	mm			
18	450	18	450	CBC18	76668	76.7
24	600	24	600	CBC24	76669	87.9
30	750	30	750	CBC30	76670	99.0
36	900	36	900	CBC36	76671	110.1
42	1050	42	1050	CBC42	76672	121.2
48	1200	48	1200	CBC48	76673	132.4
54	1350	54	1350	CBC54	76674	143.5
60	1500	60	1500	CBC60	76675	154.6

Lead time: 1 working day



## Replacement Parts

REF	DESCRIPTION	ORDERING NUMBER	ITEM CODE	WT. LBS.
1	18" (450mm) Drum Shaft	CDS18	76684	15.1
	24" (600mm) Drum Shaft	CDS24	76685	17.0
	30" (750mm) Drum Shaft	CDS30	76686	18.9
	36" (900mm) Drum Shaft	CDS36	76687	20.8
	42" (1050mm) Drum Shaft	CDS42	76688	22.7
	48" (1200mm) Drum Shaft	CDS48	76689	24.6
	54" (1350mm) Drum Shaft	CDS54	76690	26.4
	60" (1500mm) Drum Shaft	CDS60	76691	28.3
2	Chevron Pillow Block*	CPB	76692	1.2
3	18" Replacement Drum*	CRD18	76676	27.7
	24" Replacement Drum*	CRD24	76677	37.0
	30" Replacement Drum*	CRD30	76678	46.2
	36" Replacement Drum*	CRD36	76679	55.4
	42" Replacement Drum*	CRD42	76680	64.7
	48" Replacement Drum*	CRD48	76681	73.9
	54" Replacement Drum*	CRD54	76682	83.2
60" Replacement Drum*	CRD60	76683	92.4	
4	Mounting Bracket Kit (1 Right and 1 Left)	EZS2MBK	75666	13.0
5	Adjusting Bracket Kit* (1 ea.)	EZS2ABK	75664	2.0

\*Hardware Included

Lead time: 1 working day

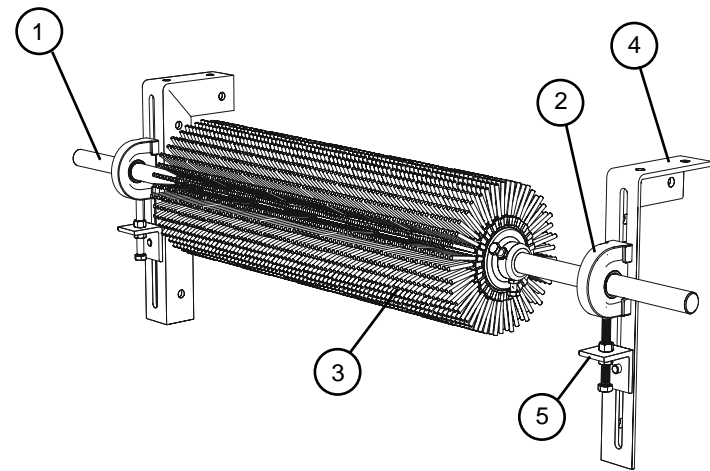

## Specifications

Belt Speed	Up to 500 fpm (2.5M/sec)
Vertical and Horizontal Clearance	10" (250mm)
Temperature Range	-30°F to 180°F (-35°C to 82°C)
Maximum Chevron or Cleat Height	1" (25mm)
Finger Length	2" (50mm)
Rubber Durometer	45A
Overall Diameter	9-1/2" (238mm)
Shaft Length	Belt Width plus 30" (750mm)
Shaft Diameter	1-3/16" (30mm)

## Product Notes:

- Free-rotating. Works only when the belt is running.
- Self-cleaning. Finger length, spacing and the rotary action allows carryback to fall free instead of clogging.
- Easy to install. Few parts and step-by-step instructions make the job simple.
- Long-wearing SBR rubber. Drum life ranges from 1 to 3 years depending upon the application conditions and the material being conveyed.
- Works on reversing belts.

**Eliminator®**  
BELT CLEANING SYSTEMS