

# **LIGHTWEIGHT #95 LACER OPERATION MANUAL**

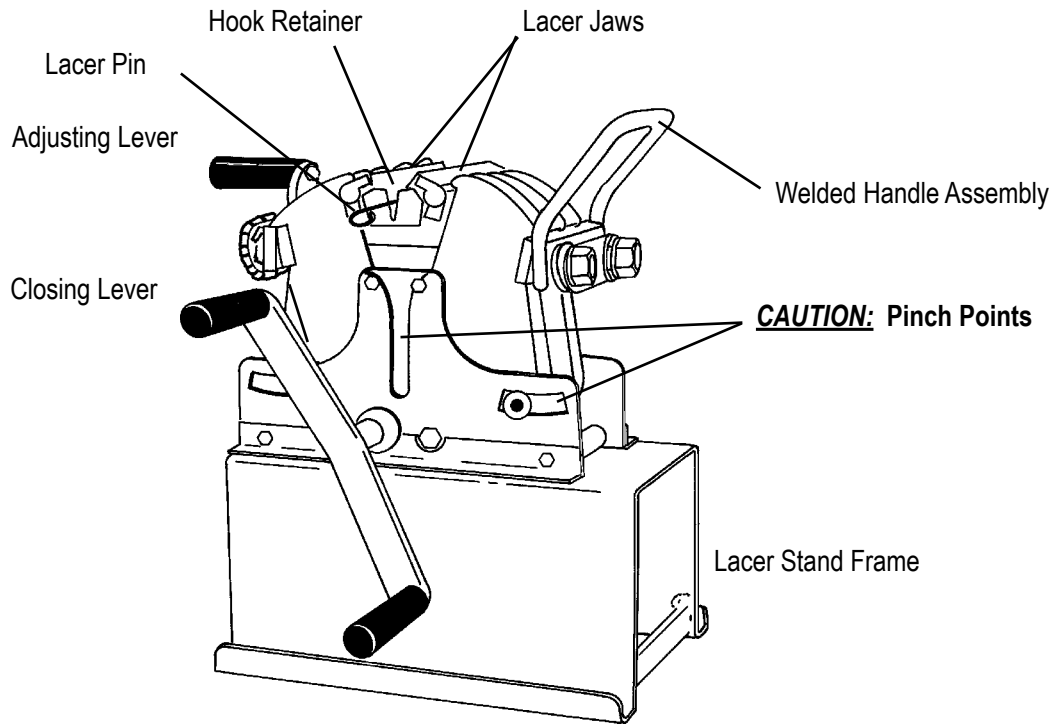





**Assemble Stand and Closing Lever**

1. Align lacer to holes on stand. Attach with screws, lock washers and square nuts.
2. Closing Lever can be mounted on either side of lacer. Select side which is most comfortable, place handle on pinion shaft and tighten screw.

**Prepare belt**

1. Square belt end
  - A. Measure diagonally across belt 6" (150mm) longer than belt width and mark center point. Example: Measure 48" (1200 mm) diagonally across a 42" (1050mm) wide belt and mark at 24" (600mm). See Figure 1.
  - B. Repeat at least five more times, moving the tape 12" (300 mm) down the belt each time. Mark each center point.
  - C. Using a straightedge, connect as many points as possible for an average center line. See Figure 2.
  - D. Use a square to draw a perpendicular line to the center line. Cut belt on this line.
2. For rough top belt, skive back  $\frac{3}{4}$ " – 1" (19 - 25 mm).

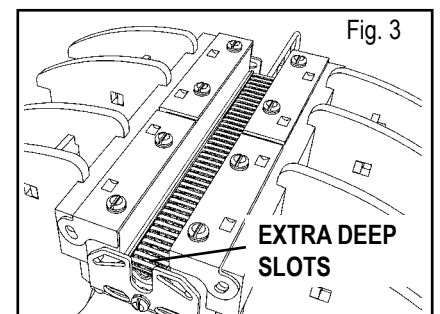
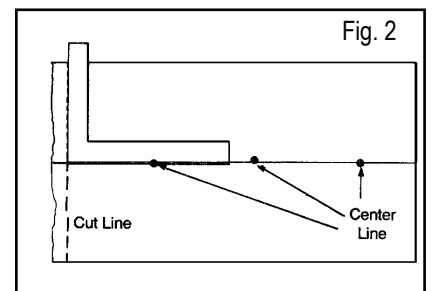
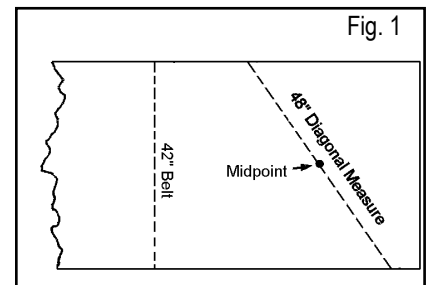

**Lacing instructions:**

1. Select the proper size hook for the application.
2. Remove lacer pin from hook retainer. Turn adjusting lever to open lacer jaws. Insert hooks in active slots of hook retainer (no hooks in the two extra deep slots). See Figure 3. Reinsert lacer pin.
3. Close adjusting lever until hooks are held firmly between jaws.
7. Belt edges should line up when ends are connected.
8. Run fingernail across hooks of splice; hook loops should not move.

- Clipper hooks are available in two carded styles and one Unibar style. Referring to the below drawings, identify the type of lacing you have selected. See Figures 4, 5 and 6.

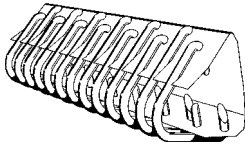

Fig. 4

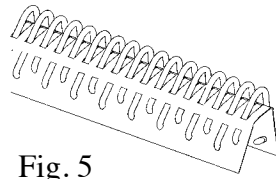

Fig. 5

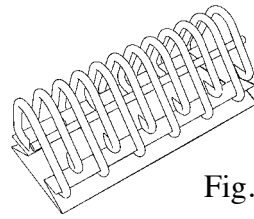

Fig. 6

Insert hooks into hook retainer and secure with lacer pin. If using hooks shown in Figure 4 or 6, remove carding paper. Carding paper as shown in Figure 5 is removed *after* the splice is complete.

- Hold belt down flush and perpendicular onto the hook retainer.
- Holding belt with one hand, turn closing lever with other hand to embed hooks into the belt. Once hooks are started into the belt, both hands can be used to finish cycling the closing lever. Ensure fingers and foreign objects are free from crank, chain and pinch points.
- Open jaws and examine hook clinch. Hooks are properly clinched when a.) approximately 1/2 the diameter of hook leg is imbedded into the belt; b.) Hook points barely penetrate opposite side of belt.
- If additional clinch is required, turn adjusting lever clockwise 1/8 turn and cycle closing lever again. Continue until hooks are properly clinched.
- Remove lacer pin.

### **Continuous Lacing Wide Belts**

- After first lacing operation is complete, note position of adjusting lever; this will be the "Final Set" point for future sections. This ensures a consistent splice from section to section.
- Position hook retainer with extra deep slots on the left end of retainer.
- Turn adjusting lever counter-clockwise one complete turn to open jaws.
- Insert card of hooks into hook retainer. Insert lacer pin through hook loops, but not into the extra deep slots. Turn adjusting lever clockwise until hooks are firmly held in jaws. Remove paper if applicable (Figures 4 and 6 above).
- Insert last two laced hooks into the extra deep slots (Figure 3). Continue inserting lacer pin through these hooks.
- Cycle closing lever. Turn adjusting lever to "Final Set" position (See above Step 1). Cycle closing lever. Complete additional 6" (150mm) sections as necessary until entire belt width has been laced.

### **Lacing Hints**

- Select the proper hook based on belt thickness and pulley diameter.
- Hook is properly sized and clinched when:
  - Hook legs are parallel. Hook loop should not have a light bulb shape.
  - Hook points slightly penetrate opposite side of belt (.005" - .015").
  - 1/3 to 1/2 of the wire diameter is embedded into the belt.
  - When installed, the "knuckles" of the hook should not be higher than the legs.
- Leave 1/4" on each edge of belt unlaced. This guards against end hooks being pulled out.
- Use one more hook on leading edge than on trailing edge.
- Chamfer trailing edge.
- Splice should be uniformly embedded across the entire width of the splice.
- Belt edges should line up when ends are connected.
- Run fingernail across hooks of splice - hook loops should not move.

Good Clinch: Hook legs are parallel, half of the wire diameter is embedded into belt, and hook points have penetrated through belt.

Over Clinch: Functional, but not an optimal splice. Try to avoid overclinching in the future.

Under Clinch: Embed fasteners further.

### ***Maintenance***

1. Oiling - Oil all moving parts, chain and thread of tie rods, underneath lacer: rack assembly and toggle link pins.
2. Cleaning - Blow off the lacer with air hose periodically to free dust and dirt.

# PARTS LIST

## Light Weight #95 & #25 XLW Lacer Parts

- 03016 12-24 x 3/8" Round Head Screw
- 03486 1/4 Spring Lock Washer
- 03077 Jaw Bar Assembly #2
- 03078 10-24 x 1-3/4 Zinc Plated Rnd Hd Bolt
- G0368 12-24 x 1 Zinc Plated Round Head Screw
- 03079 Connecting Cable
- 03080 End Plate Assy. Includes 03111, 03094, 03016, 03079
- 03082 Long Rocker Bar
- 03083 Untapped Flat Pressure Bar
- G0373 Jaw Plate Spacing Collar
- 03088 Frame Anchor
- 03089 Trunnion Washer
- G0374 10-24 Zinc Plated Square Nut
- 03091 3/4-16 Hex Jam Nut
- G0377 Long Jaw Plate Shaft Collar
- G0378 Medium Jaw Plate Shaft Collar
- G0379 Short Jaw Plate Shaft Collar
- 03092 Adjusting Lever
- 03093 #8-1/16 x 3/64 Lock Washer
- 03094 #12-1/16 x 1/16 Lock Washer
- 03095 Spring Washer
- 03096 Tie Rod Spring
- 03097 8-32 x 5/16 Zinc Plated Round Head Screw
- 03485 1/4-20 x 1-1/2 Zinc Plated Hex Head Screw
- 03100 Long Tie Rod Assembly
- 03101 Short Tie Rod Assembly
- 03102 Nut Anchor Assembly
- 03498 Chain Assembly
- 03106 Jaw Assembly
- 03108 Regular Acusteel™ Hook Retainer
- 03109 L.H. Jaw Wing
- 03110 R.H. Jaw Wing
- 03111 End Plate
- 03112 Jaw Plate
- 03113 Jaw Bar Assembly #1

- 03118 Hook Retainer to Jaw Assembly includes: 03016, 03094, 03108, 03153, 03097, 03093, 03106, 03109, 03110, 03079
- 03122 Welded Handle Assembly
- 03153 Regular Lacer Pin
- 03188 3/8 Regular Spring Lock Washer
- 03245 Plastic Knob
- 03246 Plastic Knob Sleeve
- 03248 3/8-16 Hex Nut
- 03249\* Flanged Nut 3/4-16
- 03258 Nut Jam 3/4-16 Nylon Insert
- 03262 3/8-16 x 2-3/4 Rd Hd Screw

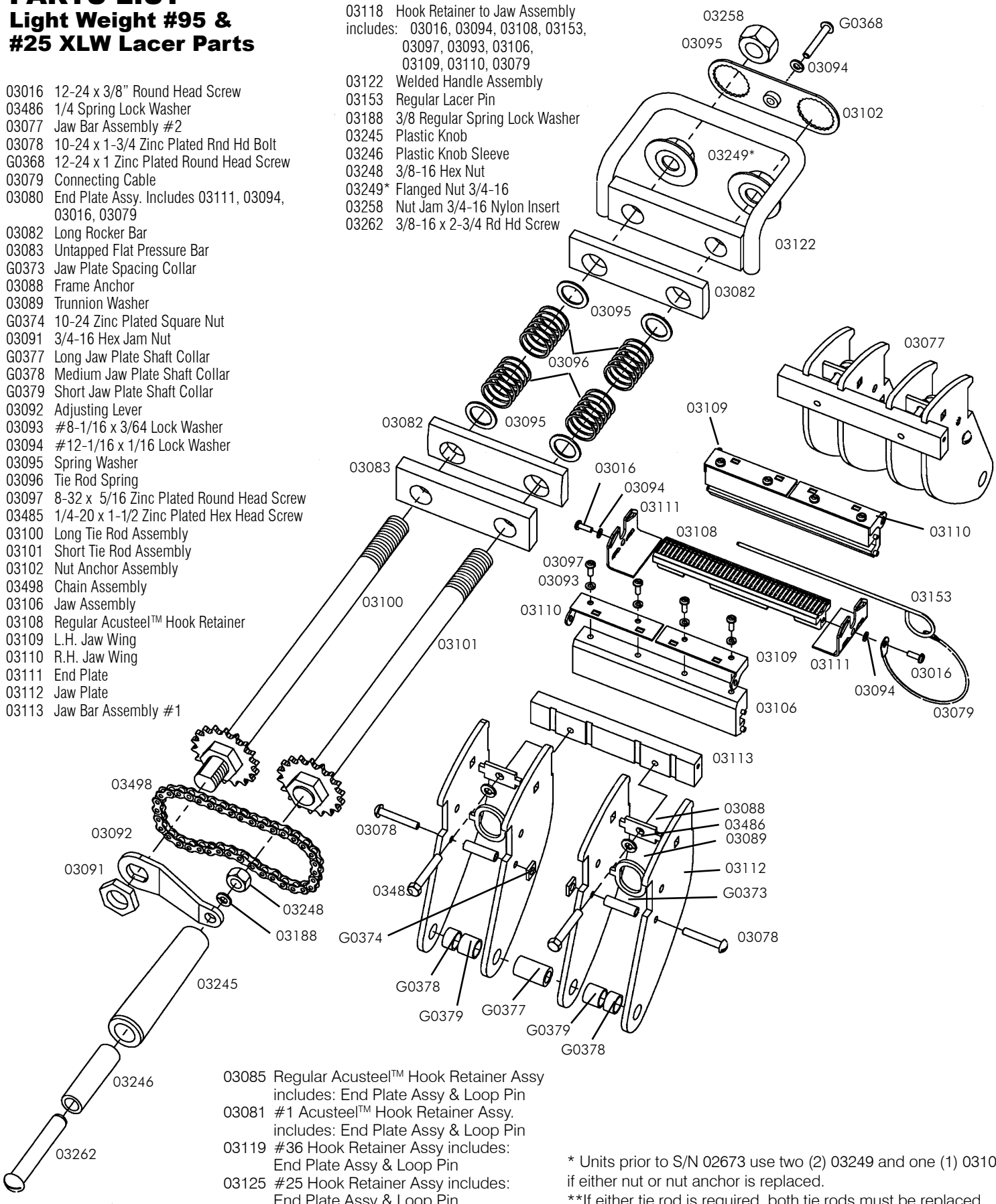

- 03085 Regular Acusteel™ Hook Retainer Assy includes: End Plate Assy & Loop Pin
- 03081 #1 Acusteel™ Hook Retainer Assy. includes: End Plate Assy & Loop Pin
- 03119 #36 Hook Retainer Assy includes: End Plate Assy & Loop Pin
- 03125 #25 Hook Retainer Assy includes: End Plate Assy & Loop Pin

\* Units prior to S/N 02673 use two (2) 03249 and one (1) 03102 if either nut or nut anchor is replaced.  
 \*\*If either tie rod is required, both tie rods must be replaced.

- 03086 Detent Spring
- 03087 Sliding Block
- 03090 Rack Support Roller
- 03099 Jaw Plate Shaft
- 03104 Long Pinion Shaft Assy
- 03105 Rack Assembly
- 03114 Closing Lever Assembly - with handles
- 03115 Rear Side Plate Assembly
- 03116 Front Side Plate Assembly
- 03121 3/8-24 x 5-1/2" Hex Head Cap Screw
- 03123 10-24 x 1/2 Thumb Screw
- 03137 Replacement Handle Assy
- 03188 3/8" Lock Washer
- 03189 3/8-24 Hex Jam Nut
- 03227 3/8" Flat Washer
- 03245 Plastic Knob
- 03246 Plastic Knob Sleeve
- 03248 3/8-16 Hex Nut
- 03262 3/8-16 x 2-3/4 Round Head Screw
- 03470 E Clip 3/8
- G0375 Link Pin Roller
- G0376 Lower Frame Rod Collar
- G0380 Toggle Link Pin
- G0381 Toggle Link
- G0388 Upper Frame Rod
- G0389 Rack Support Roller Shaft
- G0410 3/8" Lock Washer
- G0714 Keps Nut, 1/4-28

