



Electric-Hydraulic Lacer *Operation Manual*



INTRODUCTION

Congratulations on your purchase of a Clipper® Electric Hydraulic Lacer. This lacer is a vital part of the best Wire Hook System available today.

The Clipper Electric-Hydraulic Lacer is the fast, reliable method of handling all of your production belt lacing needs. Your lacer can be plugged into any compatible electrical power source and the casters allow for complete mobility. Belts up to the width of the lacer can be laced in a single operation and the continuous lacing feature means you can lace any width belt. With the use of optional hook retainers, this lacer can install any size Clipper hook.

This operation manual has been compiled for your use. PLEASE READ THE MANUAL CAREFULLY BEFORE ATTEMPTING TO USE YOUR LACER EVEN IF YOU ARE FAMILIAR WITH THE MACHINE. The manual provides important information regarding the lacer and proper lacing procedures for your safety.

If you have any questions about your lacer, please contact your Flexco Distributor or our Customer Service Department. Be sure to use the identification information listed below.

<p>Your Lacer Identification</p> <p>Model No. _____</p> <p>Serial No. _____</p> <p>Date Purchased _____</p>

Please use correct model number and serial number when corresponding with your Flexco Distributor or with Flexco Customer Service. Proper identification will help us to quickly and efficiently answer your question or service you with repair parts.

Thank you,

Flexco



1995 Oak Industrial Dr. NE • Grand Rapids, MI 49505 U.S.A.
Telephone: (616)-459-3196 • Fax: (616)-459-4976 • E-mail: info@flexco.com • Web: www.flexco.com

Australia: 61-2-9680-3322 • China: 86-21-33528388 • England: 44-1274-600-942
Germany: 49-7428-9406-0 • Mexico: 52-55-5674-5326 • South Africa: 27-11-608-4180

©2007 Flexible Steel Lacing Company. Clipper®, Unibar® and Flexco® are registered trademarks.
U.S. Patent No. D482,508S. 7/07. Lit Code: 1164





TABLE OF CONTENTS

Lacer Identification Information	Inside Front Cover
Lacer Picture	2
Preparing Your Lacer For Operation	2
For Your Safety	3
Proper Lacing Procedures	4
Lacing Accessories Kit	4
Preparing the Belt for Lacing	4
Loading the Hook Retainer	5
Lacer Operation	5
Continuous Lacing Wide Belts	6
Using a Filler Strip	6
Changing Hook Retainers	6
Lacing Tips and Advice	7
Optional Clipper Accessories	7
Readjusting the Lacer Jaws	8
Maintenance	8
Troubleshooting	9
Parts List.....	10
Lacer Stand and Hydraulic Components.....	12
General Specifications.....	Inside Back Cover

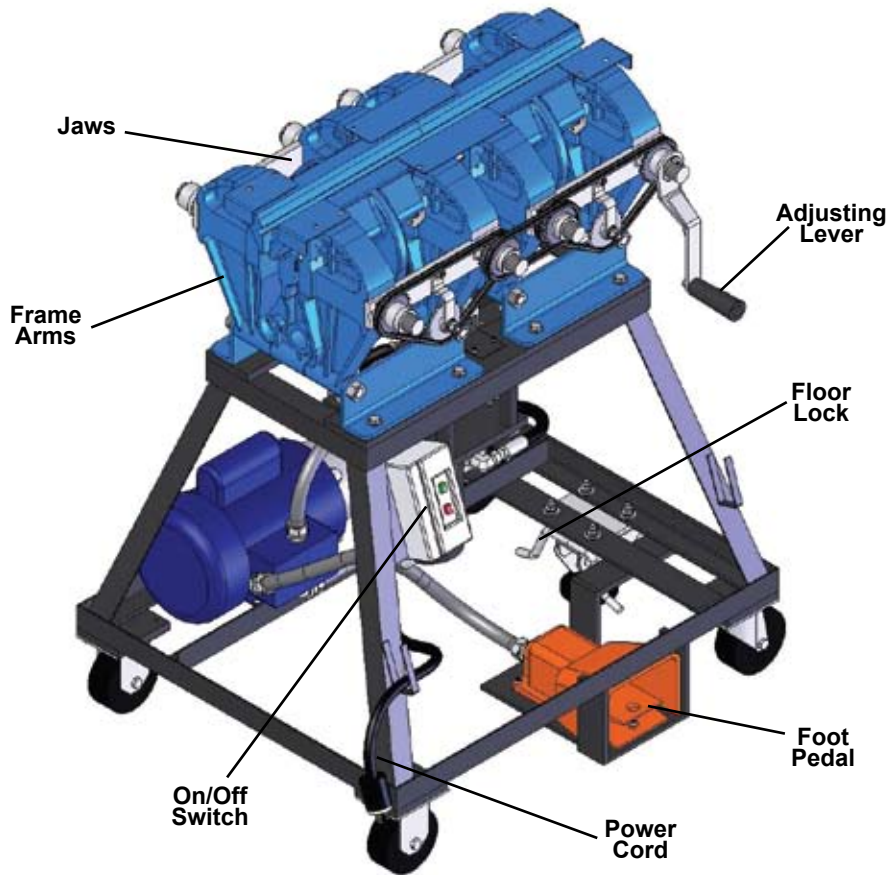

Preparing Your Lacer For Operation

1. Remove package containing hook retainer(s) and lacer pin(s) and set them aside for the moment.
2. Set floor lock to stabilize lacer while you work on it.
3. Visually check fluid level. Fluid should be 1-1/2" (38 mm) below the top of the hole. Install breather cap. Screw in the breather cap hand tight. **IMPORTANT:** Breather cap must be installed or pressure buildup may result in damage to lacer. Note: You may want to save the shipping plug for use again in the event the lacer is transported to another location.
4. Remove tag from power cord and double-check that the lacer's voltage is compatible with your power source.
5. Plug in power cord and turn On/Off switch to the 'On' position. As an energy-saving feature, the motor does not run until the foot pedal is depressed.

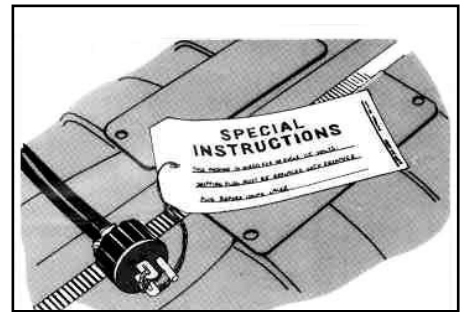
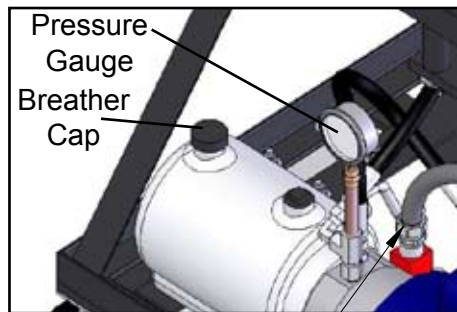
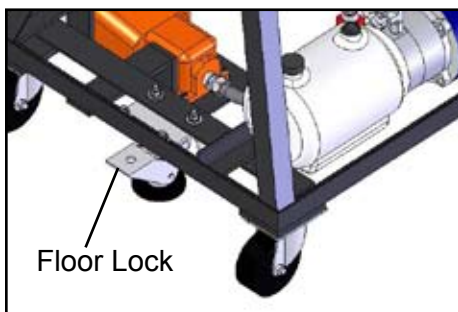

6. Step on foot pedal and cycle the lacer to be sure it is working properly. Lacer jaws will open at any point in the cycle if your foot is lifted from the pedal. Note: A slight squealing noise at mid-cycle is normal. This is caused by the hydraulic fluid going through the relief valve.
7. Install the Hook Retainer. Turn lacer off and turn adjusting lever counterclockwise to completely open the jaws. Standing in front of the lacer, insert hook retainer with continuous lacing slots on your left. Slots in bottom of retainer must fit onto plungers in the lacer. Retainer should float up and down on plungers. Hold retainer and turn adjusting lever clockwise closed until retainer fits into the slots in the jaws (Fig. A & B).
8. Use of Lacer Pin: Every hook retainer comes with a lacer pin for securing hooks in the retainer. Insert pin into the retainer. Note: To insure a proper lace, use the Clipper lacer pin only.

Your lacer is now ready for lacing. Please refer to recommended lacing procedures and safety reminders on the following pages.

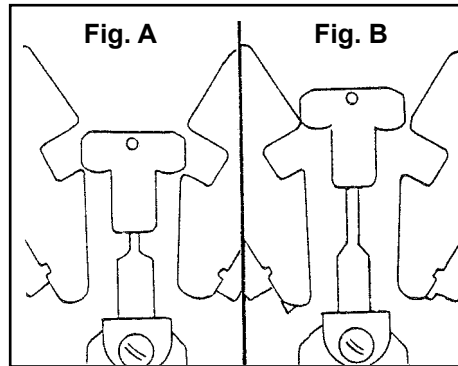
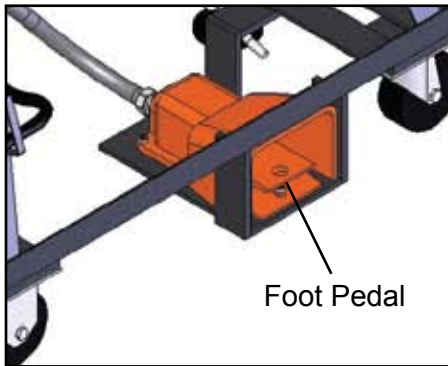

Hold down Retainer slightly so it fits into slots in jaws (Fig. A), not above slots (Fig. B).

For Your Safety:

All Electric-Hydraulic Lacers have the following safety features:

- Top Guards - To prevent fingers and other materials from getting near moving parts.
- Foot Pedal Control - Releasing pressure on foot pedal at any point in the cycle will immediately open the lacer jaws.
- Foot Pedal Guard - Foot pedal is enclosed to prevent accidentally engaging it.
- Warning Stickers - Located on top guards to continually remind the operator of safety precautions.

To Ensure Operator Safety, Follow These Simple Rules:

1. Always engage the floor lock when using the lacer.
2. Plug the lacer into power sources with proper voltage.
3. Operate lacer directly from electrical wall receptacle. If extension cord must be used, use #14 AWG for distances up to 20 feet and #12 AWG for distances greater than 20 feet.
4. Never operate the lacer with the guards removed.
5. When cycling the lacer, keep fingers, clothing and jewelry well away from closing jaws.
6. Never place tools or other foreign objects on the lacer that could fall between the jaws during operation.
7. Unplug the lacer during maintenance or repairs and when not in use.
8. Look at hydraulic lines for cracks and wear, so fluid does not leak.

Proper Lacing Procedures

Lacing Accessories Kit

Included with your lacer is a Lacing Accessories Kit. This Kit will be referred to in the following lacing steps. We recommend their use to make lacing installation as easy and fast as possible.

1. **Hook Gauge** - To select the proper size hook for your belt thickness and minimum pulley diameter.
2. **Rough Top Belt Skiver** - Removes rough top impression covers from belt for best lacing results.
3. **Carding Paper Remover** - For quick removal of carding paper from hook points. Prevents damage to hook retainer caused by using knives, screwdrivers and other sharp objects to remove carding paper.
4. **Scissors** - To cut hook cards to proper size.

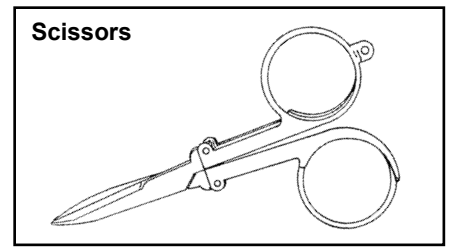
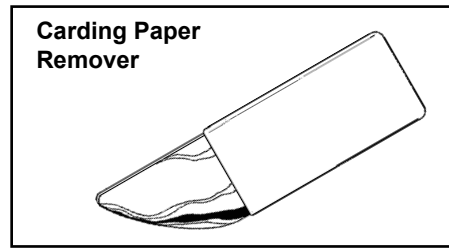
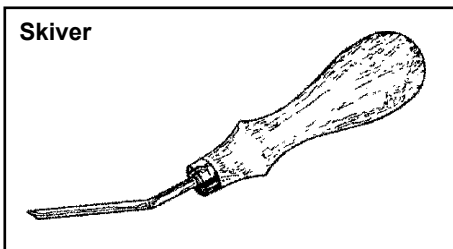
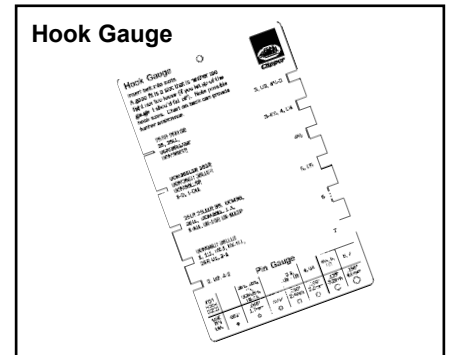

Preparing the Belt for Lacing

Preparation of your belt is as important as the actual lacing of the fasteners.

1. Square belt ends. The Clipper® 845LD Belt Cutter is a portable cutter that can provide a quick, safe, accurate cut. See Figure A. For belts with worn edges, it is necessary to find the center line of the belt. To do this, take an even measurement wider than the belt width; (Ex. 48" for a 42" belt) measure diagonally and mark the center point (Ex. 24"). See Figure B. Repeat this step at least four more times, moving the tape measure one foot along the belt for each position. See Figure C. On a typical belt with worn edges, the center points marked will not be in a straight line. Take a straight edge and draw a line as close to connecting the center points as possible. This will determine an average center line. Then draw a line perpendicular to the average center line. See Figure C. The belt end will be square when cut along this line. Use the Clipper® 845LD Belt Cutter to cut the belt.
2. Determine hook size needed. Use your Clipper Hook Gauge for general fastener size recommendations for belt thickness and minimum pulley diameter. Select the proper size hook for the application.
3. Determine the number of cards needed for the splice by laying cards of hooks across the belt end. **Note:** It is recommended that 1/4" (6-1/2 mm) on each belt edge be left unlaced. See Lacing Tips and Advice on page 7.

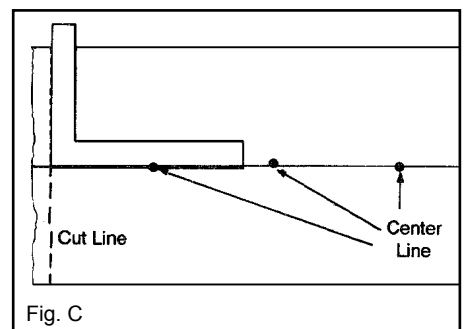
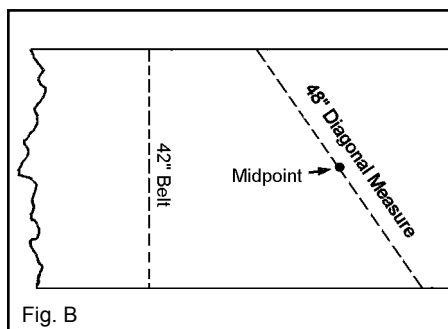
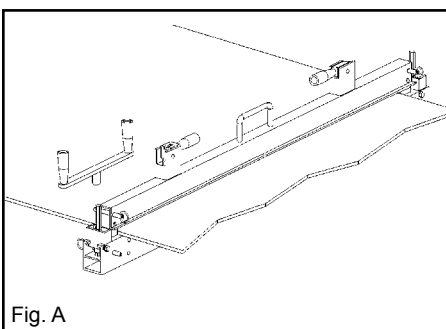

Loading The Hook Retainer

1. Turn adjusting lever counterclockwise until jaws open wide enough for hooks to fit in easily.
2. Remove lacer pin.
3. Clipper wire hooks come in two different carding styles and also in a Unibar® configuration. If using hooks as shown in Figure A, insert card(s) of hooks with carding paper reading upside down (for easy removal of carding paper). See Figure D. It does not matter which way the carded hooks as shown in Figure B or Unibar hooks are inserted into the hook retainer. Reinsert lacer pin to lock hooks in place. Hooks should not be in the two continuous lacing slots.
4. Close adjusting lever until hook legs are held firmly between jaws. Use caution to ensure fingers, clothing and/or jewelry are free from jaws while in operation. **Note:** For #1, #25, and #36 Series hooks, bringing jaws up snug to hook legs may cause over-compression on some belt thicknesses. For these hooks, size belt for proper clinch before loading hooks: Place belt between lacer jaws, cycle lacer and use adjusting lever to bring jaws up snug against belt. Tighten 1/2 to 3/4 turn. This will be your final lace position.
5. If using hooks as shown in Figure A, remove paper at this time. If using Unibar hooks, remove safety strip at this time. It is recommended to remove the carding paper from the back side of the hooks first by using the carding paper remover as shown in Figure E. Once the entire back side has been removed, uncurl the paper, grasp the paper and push it up and away from the hooks (Figure F). If using hooks shown in Figure B, the paper will remain on until after the lacing process is complete and then is removed.

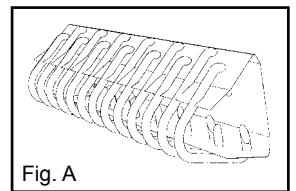

Fig. A

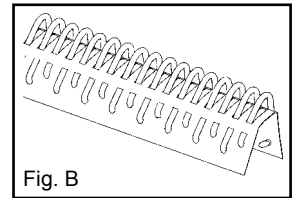

Fig. B

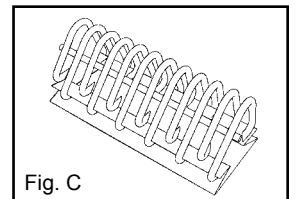

Fig. C

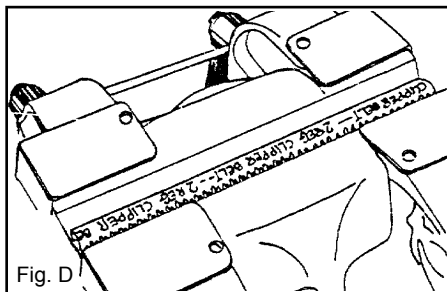

Fig. D

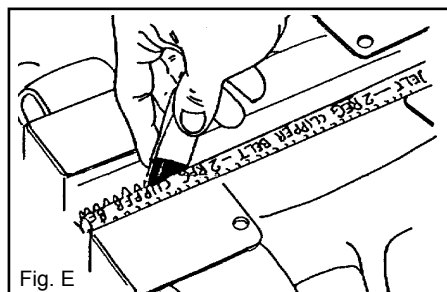

Fig. E

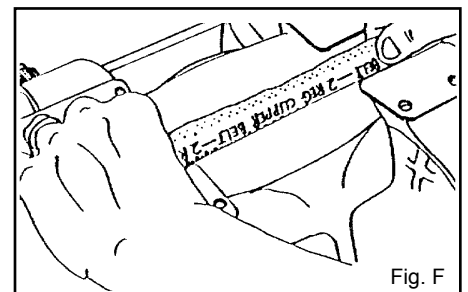
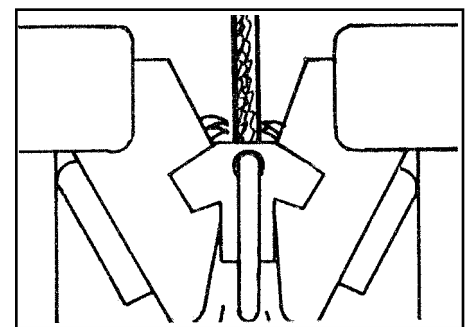

Fig. F

Lacer Operation

1. Position belt squarely over lacer. An overhead hanger or table abutting the lacer will be helpful. Leaving plenty of slack in the belt will make it easier to hold belt down on hook retainer.
2. Hold belt down flush onto hook retainer (belt end will be perpendicular to hook retainer).
3. When belt is in the proper position, depress the foot pedal. Use caution to ensure fingers, clothing and/or jewelry are free from jaws while in operation. Hold pedal down until the jaws close and stop. Let up on pedal and lacer jaws will open.
4. Examine hook clinch. Hooks are properly clinched when: 1) Approximately 1/2 the diameter of the hook leg is embedded into the belt 2) .010" to .015" (.3 - .4 mm) of the hook points are visible (On rubber belting, hook points will recede into belt cover when jaw pressure is released).
5. If further clinch is required, turn adjusting lever clockwise 1/4 turn and cycle lacer again. Continue this process until hooks are properly clinched.
6. Remove lacer pin. Pull laced belt straight up from hook retainer with a gentle rocking motion.



Continuous Lacing Wide Belts

The hook retainer has been designed with two continuous lacing slots for precision alignment of each hook on a wide belt splice. From the operator's position, the continuous lacing slots should be on the left side. It is necessary to always lace a wide belt from left to right, so the last two laced hooks can be placed in the continuous lacing slots.

1. Determine the number of cards needed for the entire splice prior to lacing. Then, any section less than the capacity of the lacer can, and should be laced first. For example, if you are using a 25" lacer to lace a 30" belt, lace the short section first. By using this method, there will always be belting between the full width of jaws and pressure exerted will be equalized. This will help keep lacer jaws in proper adjustment.
2. After the first lacing operation is complete, note the finished position of the adjusting lever (this is easy to remember by using clock positions as reference points). **IT IS VERY IMPORTANT TO COMPLETE EACH LACED SECTION WITH THE ADJUSTING LEVER IN THE SAME POSITION.** This will ensure that the hooks are all clinched exactly the same, giving maximum strength and performance.
3. Now, prepare to lace the next section of the belt. Load the hook retainer with cards of hooks. It may be necessary to turn the adjusting lever counterclockwise one turn to open the jaws for easy insertion of the new cards. Return the adjusting lever to the established finishing position. Remove carding paper.
4. Reposition lacer or belt to the next section to be laced.
5. Insert last two hooks of the laced section into the two continuous lacing slots.
6. Hold belt firmly on hook retainer. Continue with standard lacing procedures. **Caution:** If the belt is not held down firmly onto the hook retainer or if it is held at an extreme angle, a step in the lacing may occur between laced sections, and the splice will not perform to maximum capabilities.
7. Repeat this procedure across entire width of belt.

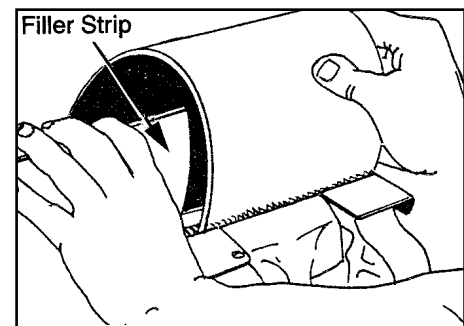
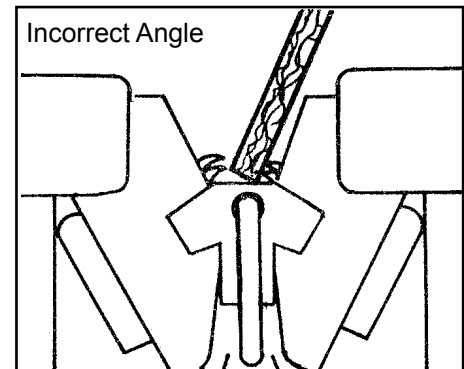
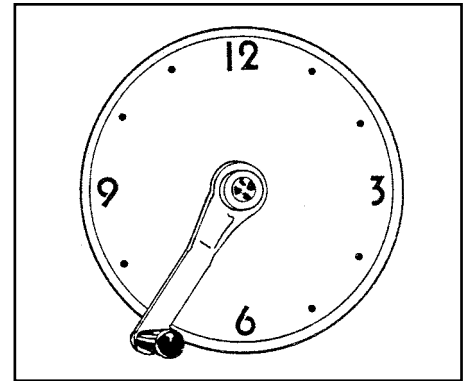
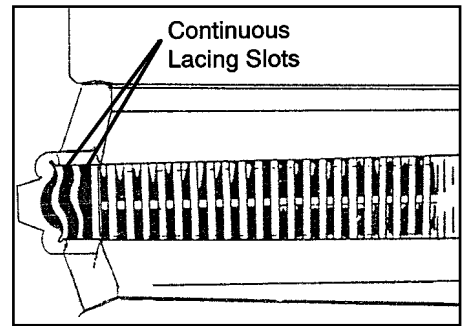

Using A Filler Strip

When lacing belts less than 3/4 of the capacity of the lacer it is recommended that a filler strip be used to equalize the pressure exerted along the length of the jaws. This can easily be done by using a scrap piece of belting the same thickness as the belt being laced. The filler strip will ensure that no undue stress will be put on the lacer that may cause damage to its parts. Failure to follow this procedure can result in broken castings, leaving the lacer inoperable.

Changing Hook Retainers

Your lacer comes standard with a regular hook retainer for lacing hook sizes #2-#7 and U2-U7. Hook retainers are available for lacing #25, #1/UX1 as well as #36/UCM36 and #30 Series hooks.

To change retainers:

1. Turn power off.
2. Turn adjusting lever (counterclockwise) to open lacer jaws.
3. Lift out hook retainer.
4. Install new hook retainer making sure the continuous lacing slots are to the left. The retainer should float up and down on the plungers.
5. Hold retainer down slightly and turn adjusting lever clockwise three turns. The retainer will fit into the slots in the jaws.
6. Store unused retainers and lacer pins in a safe place so they will not be damaged.

Lacing Tips and Advice

1. For best lacing results, use proper hook size for the belt being laced and for the pulley diameter of the system the belt will run on. Rough tops, chevrons, etc. should be skived back 1" (26 mm) from belt ends.
2. For an even belt joint, lace one less hook into trailing end of belt than on leading end.
3. Leave 1/4" (6-1/2 mm) on each edge of belt unlaced. This guards against end hooks being torn out if the belt moves against a guide or structure. Also, it is best to chamfer the corners of the belt.
4. Hook is properly sized and clinched when:
 - A. Hook legs are parallel. Loop should not have a light bulb shape.
 - B. Hook points slightly penetrate opposite side of belt (.005" - .015").
 - C. $\frac{1}{3}$ - $\frac{1}{2}$ of the wire diameter is embedded into the belt.
 - D. 'Knuckles' of the hook should not be higher than the legs when installed.
5. Use proper connecting pin for the application. Clipper provides a variety of connecting pin materials including: Durastainless™, Duralink™, Nylosteel, Nylostainless, Smooth or Notched Steel, Smooth or Notched Stainless, Nylon Covered Cable, and other miscellaneous connecting pins. The connecting pin should be one continuous length and be slightly shorter than the belt width. Another option is to cut the pin longer than the belt width and then bend the end over to hold the pin in place.

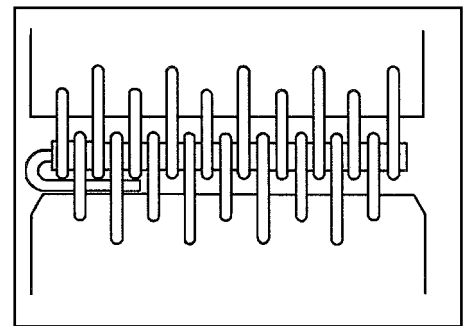
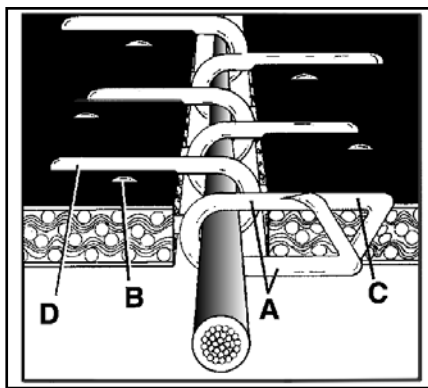
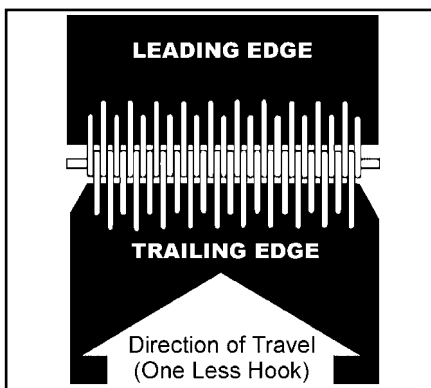

Optional Clipper Accessories

1. **Hook Retainers:** Your Electric Hydraulic Lacer comes standard with a regular hook retainer (for lacing hook sizes #2 - #7 and U2 - U7). With the addition of a #1/UX1, #36/UCM36/30 or #25 hook retainer your lacer can be easily adapted for lacing all sizes of Clipper hooks.
2. **Clipper® 845LD Belt Cutter:** Enclosed blade is driven from either end to ensure a quick and precise cut of belting and other flat materials up to 3/4" thick. Portable. Four lengths available: 36", 48", 60", and 72".
3. **Hook Gauge:** Used to select the correct hook and pin easily. Slip the belt edge into the best fitting slot and select hook size from options listed.
4. **Carding Paper Remover:** A handy tool for removing carding paper from hook points.
5. **Rough Top Belt Skiver:** Used for easy removal of rough top and other raised surfaces from belting. Skived surface ensures a low profile, long-wearing joint. Can be resharpened for years of use.
6. **Scissors:** Extra thin steel blades designed for cutting hook cards to desired length.
7. **Lacing Accessories Kit:** Includes a Hook Gauge, Carding Paper Remover, Rough Top Belt Skiver and Scissors.
8. **14" Belt Cutter:** For cutting belts up to 14" wide (350mm) square in one quick easy operation.
9. **Binder:** To prevent the ends of cotton and woven belts from fraying.

Readjusting Lacer Jaws

1. Lace a belt that is the entire width of the lacer.
2. Before removing lacer pin, mark belt at center of each frame arm (Fig.1).
3. Using a micrometer, measure hook legs (preferably a long and a short leg at the same time) at each mark on the belt. They should be within a tolerance of .004" (.1 mm). If fastener setdown varies more than .004" across width of lacer jaws, adjustment is required using these steps (Fig. 2).
4. If the tolerance is not within the specified amount, adjust the stationary tie rod nuts. Each notch will adjust the jaw .004" (Fig. 2). Adjusting the nuts too far will prevent the jaws from opening wide enough to allow easy removal of the hook retainer. If possible, adjust nuts out.
5. Make another sample lace, mark belt and mic the hooks. Adjust again if necessary.

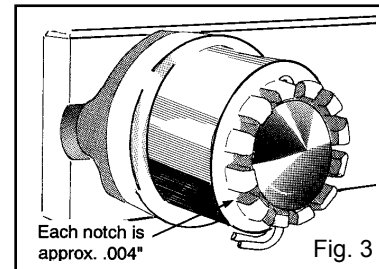
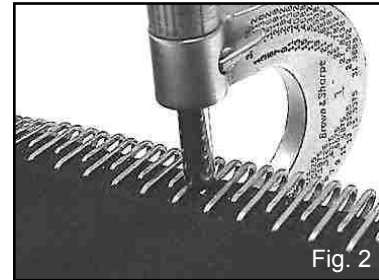
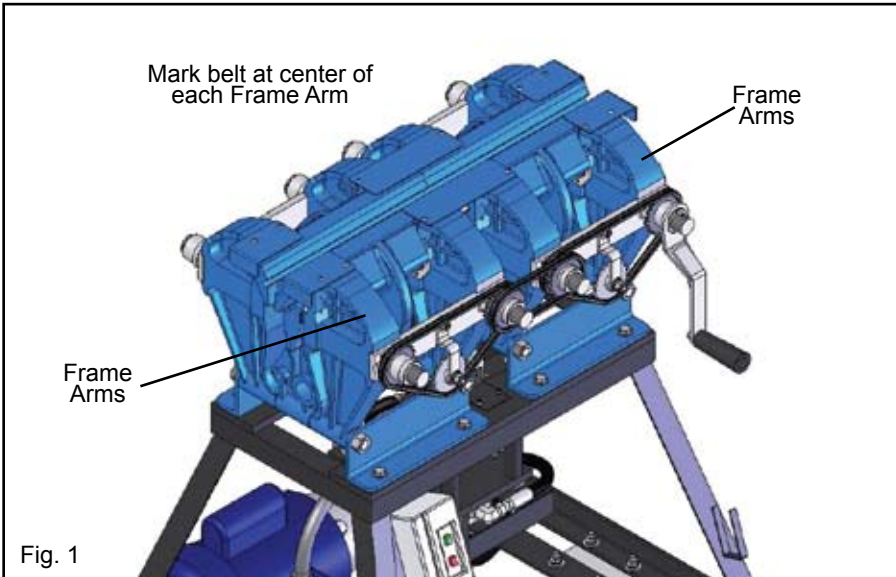

Maintenance

Your Electric Hydraulic Lacer has been designed to provide years of quality lacing. To keep you lacer in top working condition some regular maintenance is required.

The lower hydraulic system should require no regular maintenance except to check fluid level. Lacer head(s) will require periodic cleaning, oiling and adjusting.

Cleaning Using Safety Glasses:

1. Blow lacer with an air hose to free built up dust and dirt.
2. Occasionally soak hook retainer in hot water or a non-combustible cleaner to remove dirt and debris from slots. Blow dry with air hose.
3. Keep lacer covered when not in use.

Oiling:

1. Oil all moving parts including: cams, chains, tie rods, plungers, toggle shafts, toggle shaft rollers, toggle link pins, casters and floor lock (See Figs. 4 and 5).

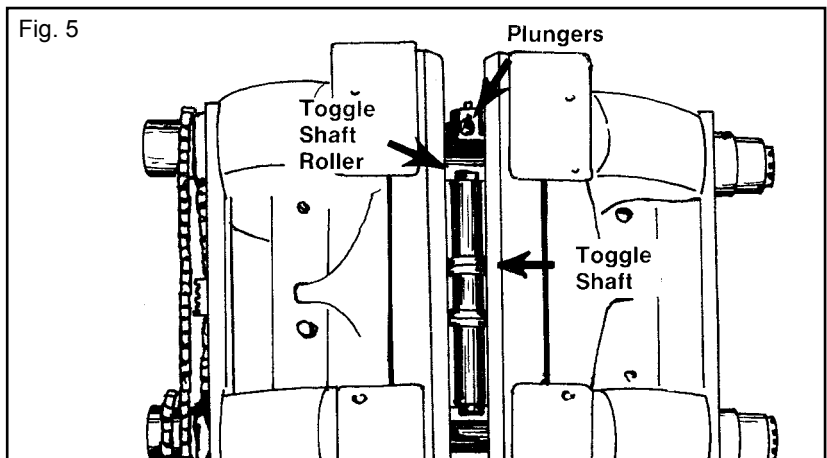
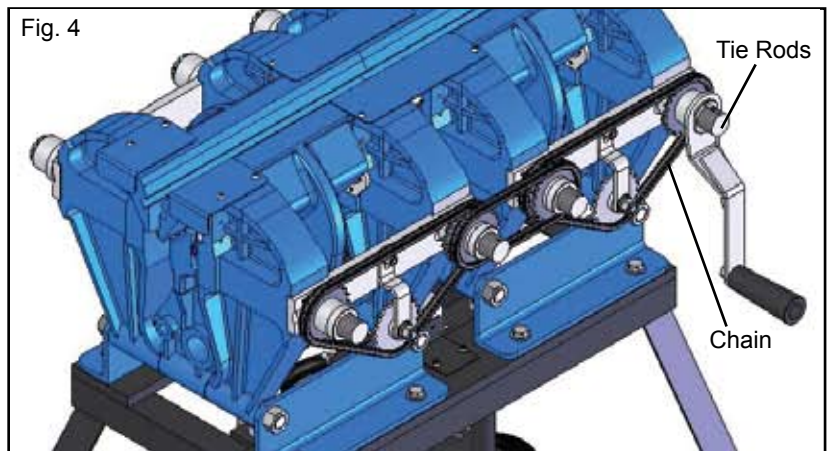

Troubleshooting:

PROBLEM

SOLUTION

Hooks are embedded deeper on one end of splice than the other end.	Check alignment of jaws. See page 8 on jaw adjustment.
Lacer makes a squealing noise when cycling.	Whenever lacer's hydraulic system must bypass main valves it will emit an audible screech. The reason for this noise is that fluid is being pumped through a small bypass valve. This is normal and will not damage your lacer.
Lacer motor won't shut off after cycling.	Check the micro switch located at the top of the lacer stand below the lacer head for proper operation.
Motor runs but the lacer won't cycle.	1) Hydraulic fluid level is low. Check level. 2) Motor pump couplings are defective. Check couplings. 3) Motor is running in the wrong direction. Check motor rotation.
Lacer runs slow.	1) Hydraulic suction screen is dirty. 2) Lacer is wired for 220 volts and is being used in a 110 volt power source. Change power source.
Lacer blows fuse in plant.	Lacer is wired for 110 volts and is being used in a 220 volt power source. Change power source. It is not recommended to run on extension cord. If necessary to use extension cord, follow instructions on page 3.
Not enough clearance between jaws to allow for removal of hook retainer.	Stationary tie rod nuts have been adjusted in too far. They must be turned out and lacer jaws readjusted. See page 8 for adjustment instructions.
During lacing cycle the lacer moves in a jerky motion.	Stop. Look for broken parts or low fluid level.
Hooks won't go into the hook retainer easily.	Examine retainer for damage to slots. Check slots for dirt buildup. See cleaning instructions on page 8.
Hooks are too sloppy (too much side play) in hook retainer.	Retainer may be excessively worn. Replace hook retainer.
Loss of pressure on the gauge.	Check hydraulic fluid level. Fluid level should be 1-1/2" (38 mm) below top of hole. Check for fluid leaks.

Parts List

ITEM	LACER	DESCRIPTION
03015	ALL	WASHER, SPRING LOCK, #10
03040	ALL	LH TOP GUARD
03926	ALL	SCRW PAN HD 8-32 x 1/2 PHILLIPS 2
03042	ALL	RH TOP GUARD
03052	25,38	CENTER GUARDS
03053	25,38	JAW CONNECTORS
03055	25,38	SNUB NOSE PLUNGER
03056	25,38	SCREW, ALLEN, 5/16-18 x 1
03058	25,38	DOWEL, 1/4 x 3/4
03172	ALL	ALIGNING BAR
G1180	ALL	SCREW, ALLEN HD, 10-32 x 1/2
03179	ALL	PIVOT WASHER ASSY
03182	ALL	SM EQUAL. SPRING WASHER
03183	ALL	LG EQUAL. SPRING WASHER
03188	ALL	WASHER, SPR LOCK, 3/8
G1252	ALL	SCREW, ALLEN HD, 5/16-24 x 5/8 BLK
03192	ALL	TOGGLE SHAFT ROLLER
03196	ALL	COTTER PIN, 3/32 x 1-1/2
03198	ALL	STATIONARY TIE ROD NUT
03200	ALL	TOGGLELINK
03201	ALL	LOWER STAY BOLT
03203	ALL	LONG UPPER TIE ROD
03204	ALL	RH CENTER FRAME ASSY
INCLUDES:		03015 WASHER, SPRING LOCK, #10
		G4827 #12 RH CENTER FRAME
		03184 PLUNGER CLIP
		03185 SCREW, FIL HD, 10-32 x 5/16
		03186 PLUNGER SPRING
		03187 PLUNGER
		#12 JAW ASSY
		G1180 SCREW, FIL HD, 10-3 x 1/2
		03193 LOWER GUIDE PIN
		03194 UPPER GUIDE PIN
		03489 OVAL PRESSURE PLATE
		G0149 SPRING PIN, 1/8 x 3/8

03456	ALL	LONG CHAIN
G0267	25	#25 ADJUSTING LEVER
G0269	ALL	TIE ROD SPRING
G0275	25,38	SPROCKET NUT ASSY
G0300	38	#38 ADJUSTING LEVER
G0302	ALL	#38 EH TOGGLE LINK PIN
G0303	38	#38 EH TOGGLE SHAFT COLLAR
02987	ALL	WSHR FLAT 5/8 PLAIN NARROW
G0526	ALL	IDLER BUSHING
G0538	ALL	NUT, HEX, 5/8-1/8
G0544	ALL	ADJUSTING TIE ROD NUT ASSY
G0550	12,25	#12/#25 EH TOGGLE SHAFT COLLAR
G0576	12	#12 ADJUSTING LEVER
G0577	ALL	IDLER SPROCKET
G0578	ALL	IDLER SPROCKET CARRIER
G0590	25, 38	SHORT CHAIN
G0614	38	SCREW, HEX HEAD, 3/8-16 x 1 3/4
G0657	ALL	E CLIP
G0247	25	EH EVENER BAR
G0296	38	EVENER BAR WELDMENT
G0272	25	PISTON CONNECTOR
03782	38	PISTON CONNECTOR
G0202	12	PISTON CONNECTOR

ITEM	LACER	DESCRIPTION
03205	ALL	LH CENTER FRAME ASSY
INCLUDES:		03015 WASHER, SPRING LOCK, #10
		G4828 #12 LH CENTER FRAME
		03184 PLUNGER CLIP
		03185 SCREW, FIL HD, 10-32 x 5/16
		03186 PLUNGER SPRING
		03187 PLUNGER
03206	ALL	RH FRAME ARM ASSY
INCLUDES:		G1180 SCREW, FIL HD, 10-32 x 1/2
		03178 RH GUIDE PLATE
		03180 FLAT PRESSURE PLATE
		03190 GUIDE PLATE SCREWS
		03271 SPRING PIN, 3/16 x 1/2
		G0516 RH FRAME ARM
03207	ALL	LH FRAME ARM ASSY
INCLUDES:		G1180 SCREW, FIL HD, 10-32 x 1/2
		03177 LH GUIDE PLATE
		03180 FLAT PRESSURE PLATE
		03190 GUIDE PLATE SCREWS
		03271 SPRING PIN, 3/16 x 1/2
		G0517 LH FRAME ARM
03208	ALL	TOGGLE SHAFT
03218	ALL	FRAME ANGLE
03227	ALL	WASHER, FLAT, 3/8
03245	ALL	HANDLE, PLASTIC
03246	ALL	HANDLE SLEEVE
03247	ALL	SCREW, ROUND HEAD, 3/8-16 x 3
03248	ALL	3/8-16 HEX NUT
03256	ALL	SCREW, HEX HD 3/8-16 x 1-1/4
03257	ALL	SPRING PIN, 3/16 x 3/4
03271	ALL	SPRING PIN, 3/16 x 1/2

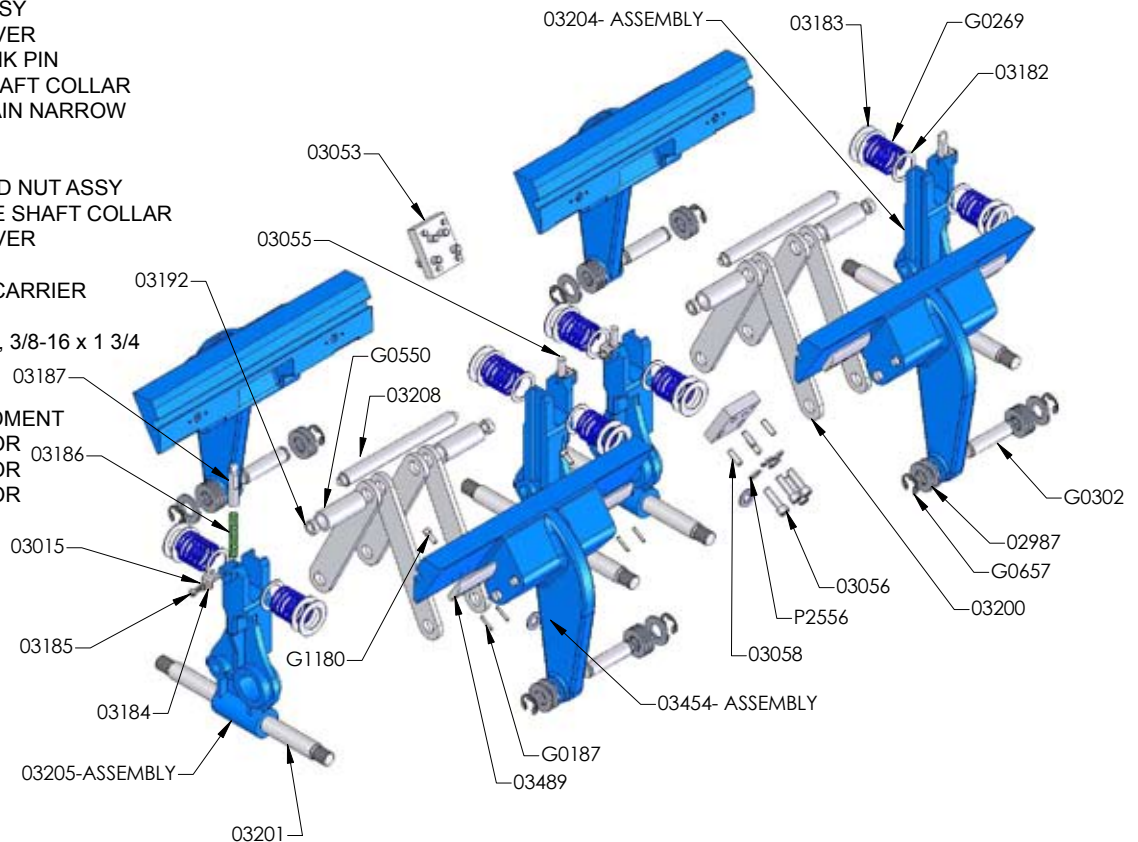

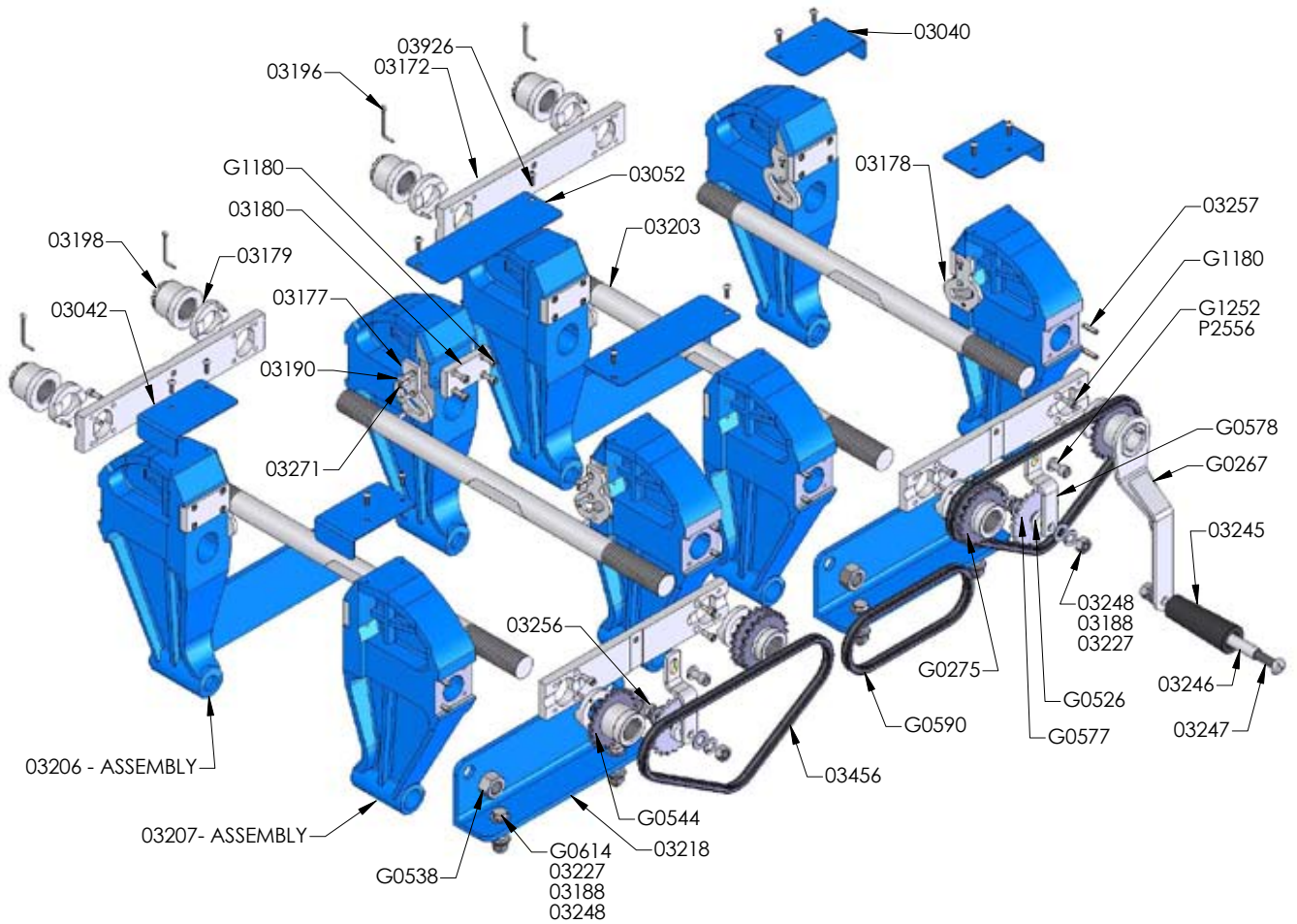
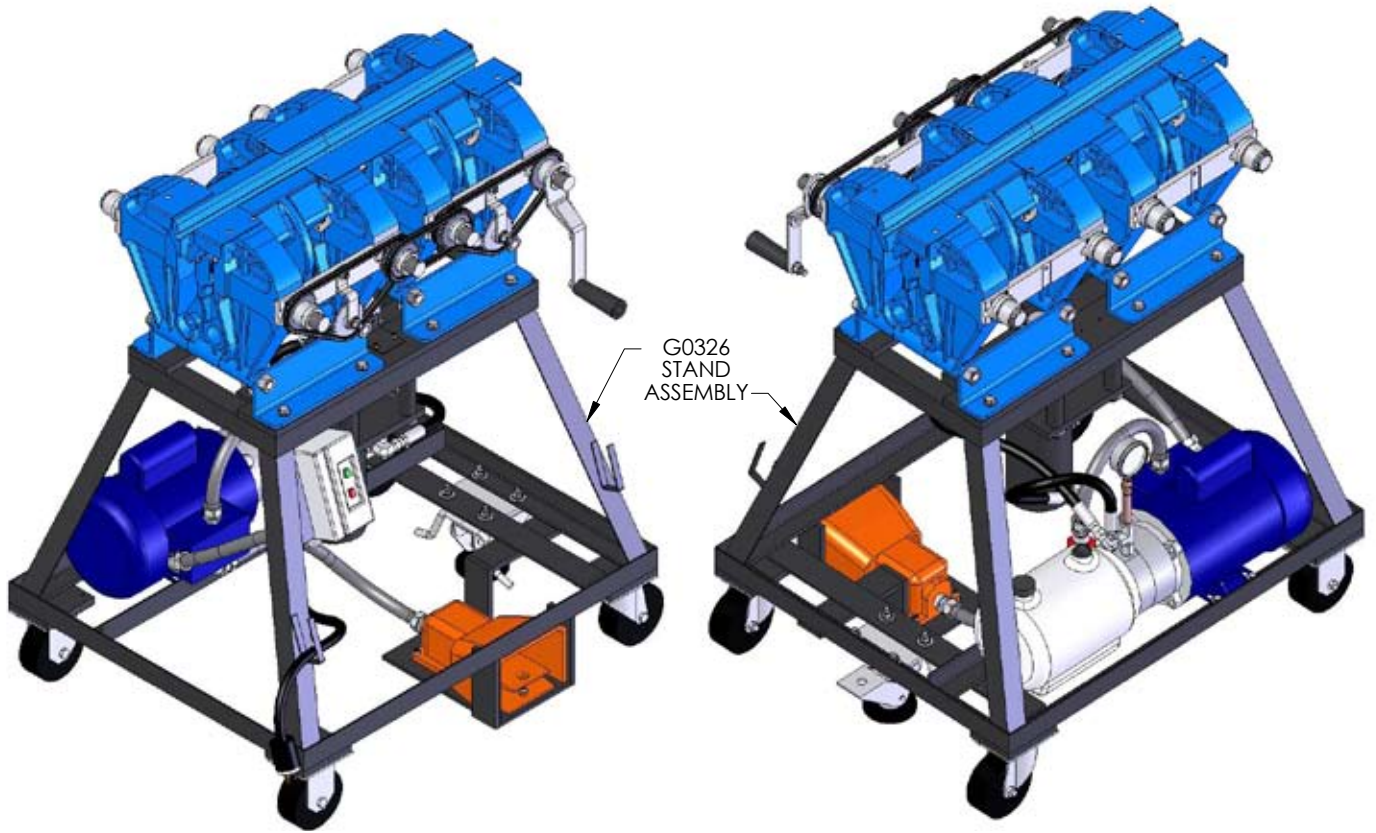

LACER STAND AND HYDRAULIC COMPONENTS

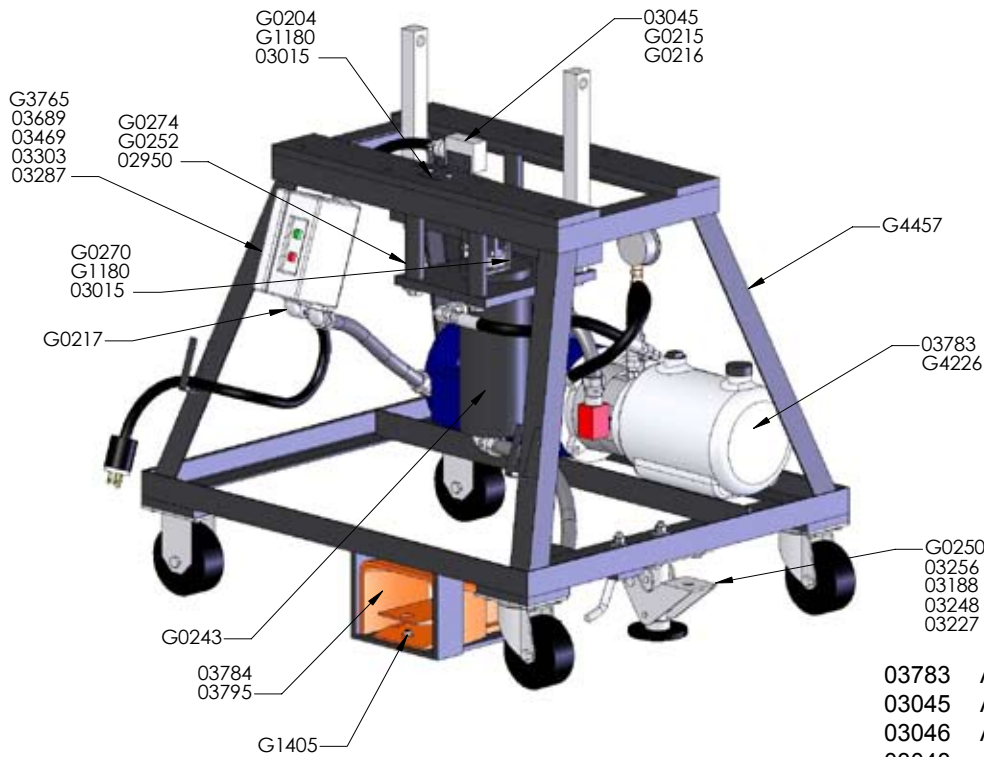

03783	ALL	MOTOR TANK & PUMP ASSY
03045	ALL	MICROSWITCH
03046	ALL	SWITCH
03048	ALL	PRESSURE GAUGE
03784	ALL	FOOT SWITCH
G0208	12	#12 HYDRAULIC CYLINDER
G0243	25	#25 HYDRAULIC CYLINDER
G0247	25	#25 EVENER BAR
G0248	ALL	SWIVEL CASTER
G0249	ALL	RIGID CASTER
G0250	ALL	FLOOR LOCK
G0274	25	#25 EH CYLINDER SPACER
G0295	38	#38 HYDRAULIC CYLINDER
G0297	38	BOLT, HEX HD, 1/2-13 x 9-1/2
G0298	38	#38 EH CYLINDER SPACER

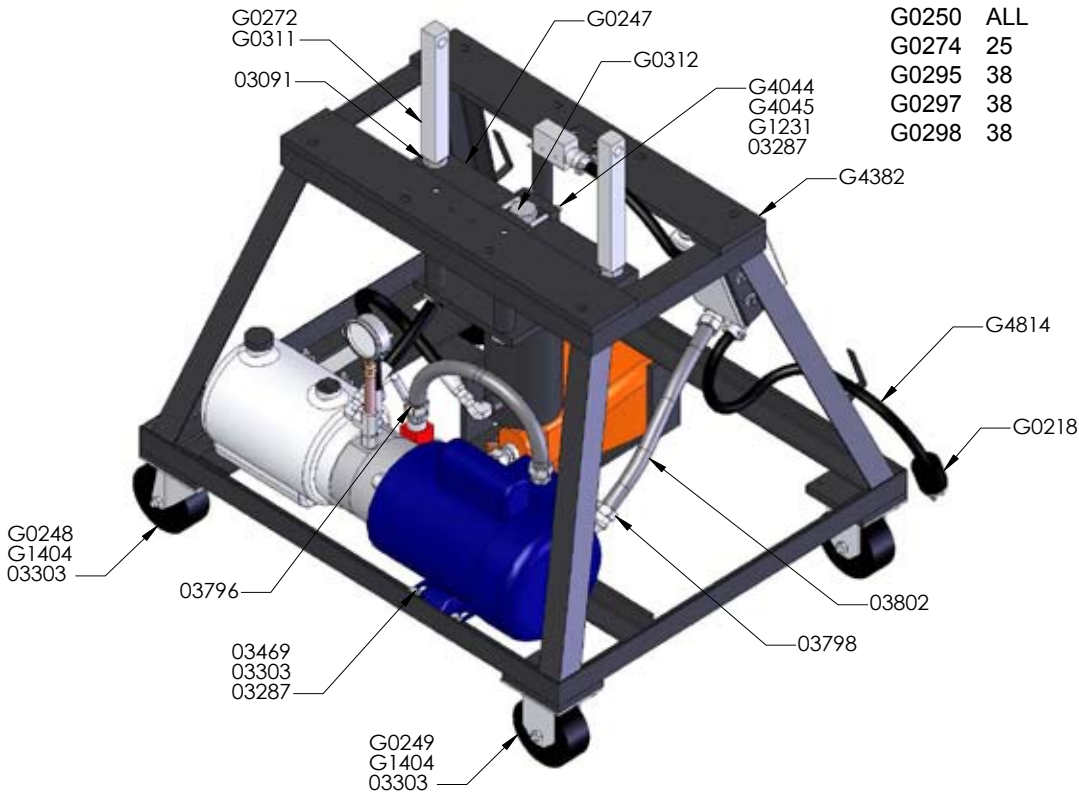

Parts List - Hook Retainers

LACER WIDTH	LACER MODEL NUMBER	HOOK RETAINERS FOR HOOK SIZES:			
		#2-#7, U2-U7 (REG. ACUSTEEL)	#1, UX-1 (#1 ACUSTEEL)	#36, UCM36, #30 (#36 ACUSTEEL)	#25 (#25 ACUSTEEL)
12"	03037	03211	03168	03170	03822
25"	03038	03051	03143	03154	03823
38"	03039	03148	03150	03155	03824

Lacer Pins (Lacer pins are supplied with each Hook Retainer)

LACER WIDTH	LACER MODEL NUMBER	REG. ACUSTEEL HOOK RETAINER	#1/#36 ACUSTEEL HOOK RETAINER	#25 ACUSTEEL HOOK RETAINER
12"	03037	03222	03169	03147
25"	03038	03054	03162	03146
38"	03039	03156	03163	03151

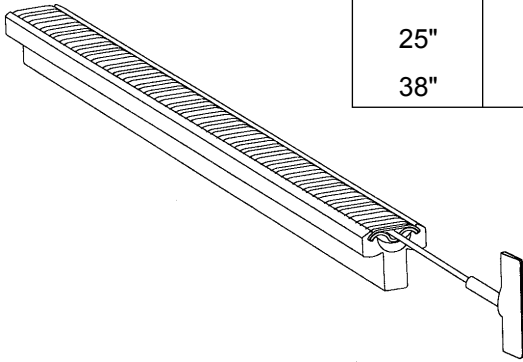

General Specifications

Hydraulic Power Supply

Positive displacement gear pump unit with built-in relief valve and fluid reservoir.

Capacity

Pump - 3.28 GPM (12 LPM)
1200 PSI (8 MPa) maximum pressure

3400 RPM

Reservoir - 3 quarts (2.8L), with breather

Hydraulic Fluid

Type A Automatic Transmission Fluid.

Hoses

3/8" (10 mm) ID, 2600 PSI (18MPa) working pressure, 8000 PSI (53MPa) bursting pressure.

Cylinder

2500 PSI (16 MPa) working pressure

Stroke - 3-5/8"

Bore - 12" Lacer - 2-1/2,
25" Lacer - 3-1/2,
38" Lacer - 4-1/2

Relief Valve Settings

Pump - 850-950 PSI (5.8-6.5 MPa)
Motor - Split Single Phase, 110/220 VAC 60 cycle.
3450 RPM, direct coupled.

Electric Power Supply

Manual Starter

Open type - 2 pole 110-220 VAC/DC with overload protection.

Micro Switches

- 25A - 110 VAC, 480 VAC MAX

Dimensions & Weights

12" Length 20" (508 mm)
Width 30" (760 mm)
Height 41" (1040 mm)
Weight 270# (128 kg)

25" Length 30" (760 mm)
Width 25" (630 mm)
Height 38" (960 mm)
Weight 450# (205 kg)

38" Length 39" (990 mm)
Width 26" (660 mm)
Height 38" (960 mm)
Weight 670# (305 kg)



1995 Oak Industrial Dr. NE • Grand Rapids, MI 49505 U.S.A.
Telephone: (616)-459-3196 • Fax: (616)-459-4976 • E-mail: info@flexco.com • Web: www.flexco.com

Australia: 61-2-9680-3322 • China: 86-21-33528388 • England: 44-1274-600-942
Germany: 49-7428-9406-0 • Mexico: 52-55-5674-5326 • South Africa: 27-11-608-4180

©2007 Flexible Steel Lacing Company. Clipper®, Unibar® and Flexco® are registered trademarks.
U.S. Patent No. D482,508S. 7/07. Lit Code: 1164

