

# INSTRUCTIONS FOR USING UNIBAR® FASTENERS



Unibar® Fasteners are designed so that all the hooks are joined together to work as a single unit. Each hook is welded to a common bar. This is particularly important in applications where there is fear of single hook loss, where belt wave is a problem after lacing, or where the fasteners need added protection against impact damage.

## Cutting Unibar to proper length:

1. If using less than a full strip, separate by:
  - a. Cutting safety strip between hooks at desired length (Fig. 1).
  - b. With thumbs touching at cut point, twist hooks apart (Fig. 2).

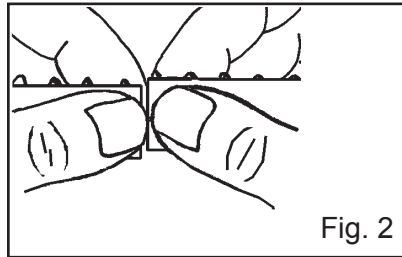
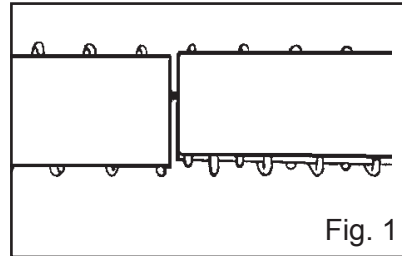

NOTE: Special length strips are available upon request. Please contact Customer Service for assistance.

**Caution:** Do not install welded bar on top of belt in live roller applications.

## NOW AVAILABLE:

Unibar® Cutters -- a hand-held tool to cut all sizes of Unibar to specific lengths.

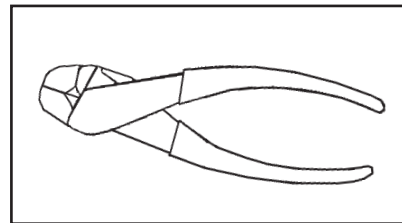

## UNIBAR® SERIES SPECIFICATIONS

Hook Size	Belt Thickness		Minimum Pulley Diameter		Recommended Connecting Pin	Wire Diameter of Hook
	Inches	mm	Inches	mm		
UCM36 SL XSP	Up to 1/16"	Up to 1.6	15/16"	24	#25	.036 x .027
UCM36 XSP	Up to 1/16"	Up to 1.6	2"	51	#25	.036 x .027
UCM36 SL SP	1/16" - 3/32"	1.6 - 2.4	15/16"	24	#25	.036 x .027
UCM36 SP	1/16" - 3/32"	1.6 - 2.4	2"	51	#25	.036 x .027
UCM36 LL SP	1/16" - 3/32"	1.6 - 2.4	3"	76	#25	.036 x .027
UCM36	3/32" - 1/8"	2.4 - 3.2	2"	51	#25	.036 x .027
UCM36 LL	3/32" - 1/8"	2.4 - 3.2	3"	76	#25	.036 x .027
UCM36 LP	1/8" - 5/32"	3.2 - 4.0	2"	51	#25	.036 x .027
UX-1 SP	1/16" - 1/8"	1.6 - 3.2	2"	51	#25, #13	.040
UX-1	1/8" - 5/32"	3.2 - 4.0	2"	51	#25, #13	.040
UA2	1/8" - 5/32"	3.2 - 4.0	2"	51	#13	.047
UA3	5/32" - 3/16"	4.0 - 4.8	2"	51	#13	.047
U3-1	1/8" - 5/32"	3.2 - 4.0	3-1/2"	89	#13	.054
U2, U3-2	5/32" - 3/16"	4.0 - 4.8	3-1/2"	89	#13	.054
U3	3/16" - 7/32"	4.8 - 5.6	3-1/2"	89	#13	.054
U4	7/32" - 1/4"	5.6 - 6.4	5"	127	#12	.054
U5	9/32" - 5/16"	7.1 - 7.9	5"	127	#11	.054
U6	5/16" - 11/32"	7.9 - 9.0	6"	152	#9	.054
U7	11/32" - 25/64"	9.0 - 10.0	7"	175	#9	.054

Standard length strips are: 6", 12" and 24". Special length strips are available upon request (4" to 60").

**Note:** UCM36 products are available in 12" and 24" lengths standard. Special length strips also available (4" to 60").

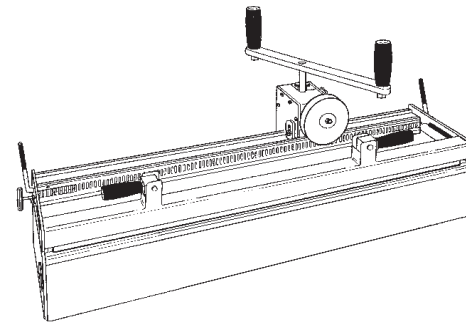

## ROLLER LACER®

Specifically designed for lacing wide belts on site in one easy operation, making it the ideal tool for quick maintenance splicing. Available in 24", 36", 48" and 60" widths.

## MICROLACER®

Ideal lacer to economically install quality splices up to 14" wide in one easy operation. Can be taken to job site.

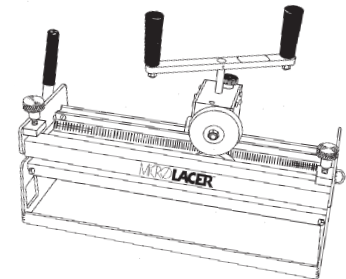

1995 Oak Industrial Dr. NE • Grand Rapids, MI 49505 U.S.A.  
 Telephone: (616)-459-3196 • Fax: (616)-459-4976  
 E-mail: info@flexco.com • Web: www.flexco.com

