

Pro 600 and Pro 6000

OPERATION MANUAL



Pro 6000 Lacer Pictured.



Your Lacer Identification

Model No. _____

Serial No. _____

Date Purchased _____

Please use correct model number and serial number when corresponding with your Distributor or with Customer Service. Proper identification will help us to quickly and efficiently answer your question or service you with repair parts.



1995 Oak Industrial Dr. NE • Grand Rapids, MI 49505 U.S.A.
Telephone: (616)-459-3196 • Fax: (616)-459-4976 • E-mail: info@flexco.com • Web: www.flexco.com

Australia: 61-2-9680-3322 • China: 86-21-33528388 • England: 44-1274-600-942
Germany: 49-7428-9406-0 • Mexico: 52-55-5674-5326 • South Africa: 27-11-608-4180

©2008 Flexible Steel Lacing Company. Clipper® and Unibar® are registered trademarks.
11/08. Lit Code 1595



WE STRONGLY RECOMMEND THAT YOU READ THIS MANUAL IN ITS ENTIRETY.

Unpacking and setting up your Pro Series Lacer

1. Remove bolts from bottom of shipping crate. Using caution to lift the lacer, place it on a solid work surface, ensuring it can not roll off the edge. See page 8 for a recommended workbench.
2. Unwrap control cables. **Do not plug power cable into an electrical outlet at this time.**
3. Visually inspect machine for possible damage during shipment. If damage has occurred, contact Flexco Customer Service at 1-800-541-8028.
4. Remove bolt from hydraulic reservoir.

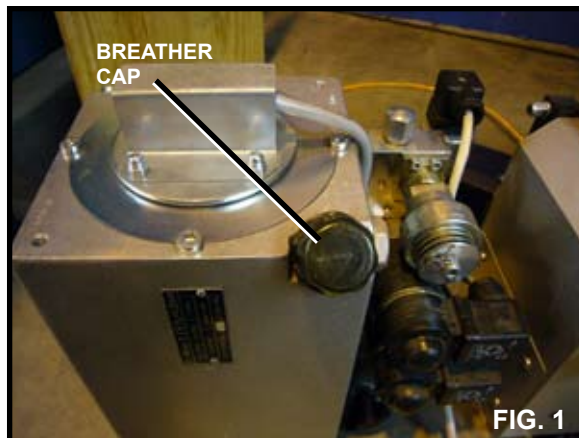

Save bolt to use if lacer needs to be transported. Screw in breather cap (See Fig. 1). Check fluid level by locating the clear fluid level viewing tube on the outside of the pump assembly. The fluid level should fill approximately $\frac{3}{4}$ of the clear tube. Add standard hydraulic fluid if level is low. Check the fluid level monthly.

Belt End Preparation

1. Square belt ends using the center line method as described below.
 - A. Take an even measurement wider than the belt width (Ex. 48" for a 42" belt). Measure diagonally and mark the center point (Ex. 24"). (See Fig. 2).
 - B. Repeat this step four more times, moving the tape measure 12" along the belt for each position. (See Fig. 3).
 - C. On a typical belt with worn edges, the center points marked will not be in a straight line. Using a straight edge, draw a line as close as possible to the center line of these points. This will be your average center line. (See Fig. 3).
 - D. Draw a line perpendicular to the average center line (See Fig. 3). The belt will be square when cut along this line.
 - E. A safe and accurate method to cut the belt is to use the portable Clipper® 845LD cutter. Cutter is available in widths from 36" – 72" (See Fig. 4).
2. Skive rough top. If belt has an impression cover, skive cover back 1" from the edge to be laced, across the entire width of the belt. Caution: Do

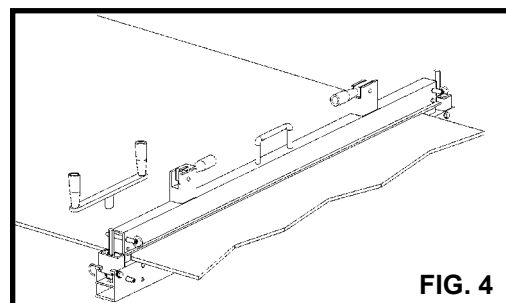
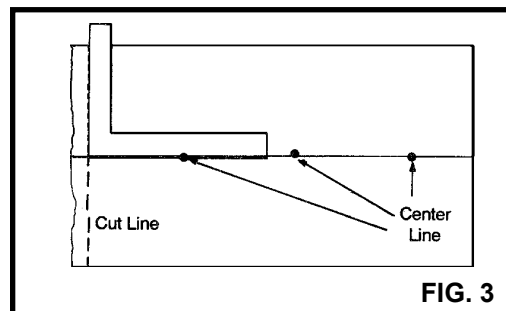
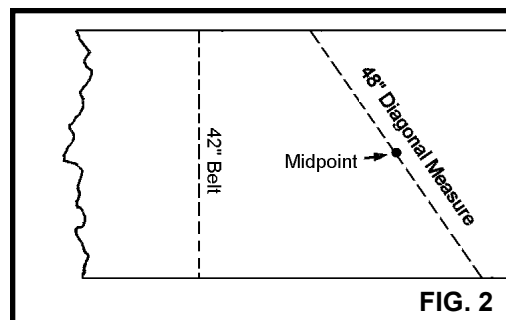

not cut into belt carcass. Measure the skived belt thickness when selecting the proper hook. (See Fig. 5).

3. Select the proper hook for the application. Refer to the enclosed “7 Steps to Selecting the Proper Fastener” brochure for additional help.

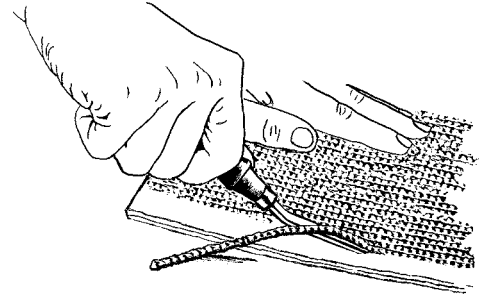

FIG. 5

Machine Preparation

1. Be sure the breather cap is properly installed (See page 1).
2. Before connecting the machine to the power supply, be sure the switch is in the “Off” position (See Fig. 6).
3. Connect the machine to the power supply
4. Select the proper comb. Proper comb is determined by the hook size you have chosen for installation. Combs are available in widths from 24" – 60". All combs have the ability to lace belts wider than the combs by using the continuous lacing feature. (See Fig. 7). Refer to the chart below to select the proper comb.

Hook Size:	Comb
25	25
36, UCM, 30	36
1, UX-1	1
2-7, U2-U7	2

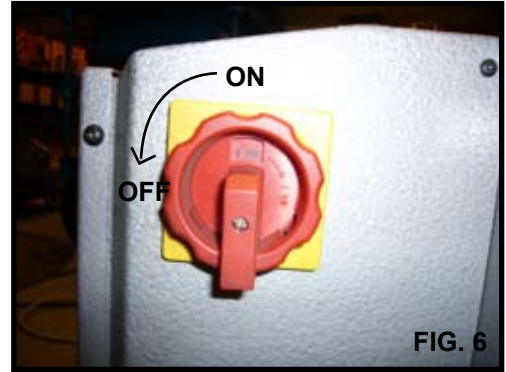

FIG. 6

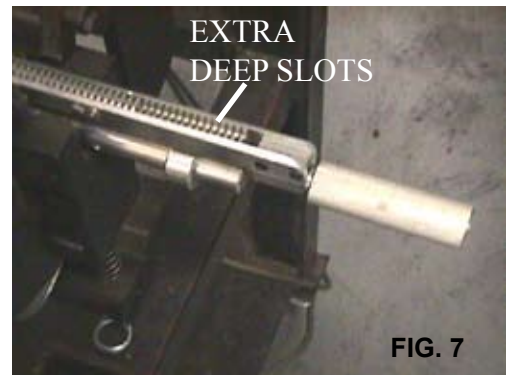

FIG. 7

5. Installing the comb:
 - A. Remove collar by loosening the set screw and sliding it off the end of the comb. (See Fig. 8).
 - B. Keeping comb level, push comb through the first bushing housing and then across the tool and into second bearing housing on the opposite side of the tool. Be sure to keep the comb level to avoid binding in the bushing housing during this operation. (See Fig. 9)
 - C. Collar is used to act as a stop. Position where desired and tighten set screw. This procedure will help ensure that the comb is not pulled out of the bushing housing when advancing the comb in the lacing procedure.
6. Selecting the correct gauge pin (lacer pin). The proper gauge pin should be 20 – 30% thinner than your belt thickness. To select the proper gauge pin, measure the belt thickness and select the

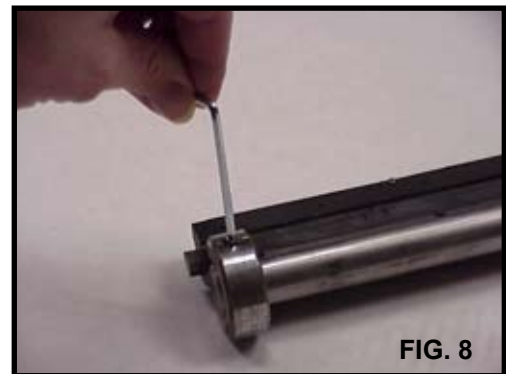

FIG. 8

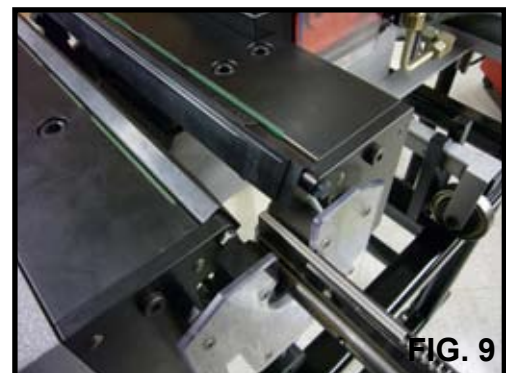

FIG. 9

appropriate gauge pin. Below is a chart showing the gauge pins that come standard with the combs.

Comb	Gauge Pins
25	1.5, 1.5 x1.8, 1.5 x 2.0mm
36	1.5, 1.5 x1.8, 1.5 x 2.0mm
1	1.8, 2.0, 2 x 2.5, 2 x 3mm
2	2.5, 3.5 x 3.0, 4.0 x 3.0mm

Determining the number of hooks required:

1. Lay strips of hooks end to end across the entire width of the belt, with the exception of $\frac{1}{4}$ " - $\frac{1}{2}$ " on each belt end. When necessary, cut a strip of hooks down to the appropriate length. Carded hooks can be cut down with a small scissors. Unibar® hooks can be cut to the appropriate length with either a Unibar® cutter or by twisting.
2. The trailing end of the belt should have one less hook than the leading end (See Fig. 10). This prevents hooks from getting caught on the conveyor framework and pulling out. The trailing end should be notched after hooks are installed to prevent belt rips/tearing.

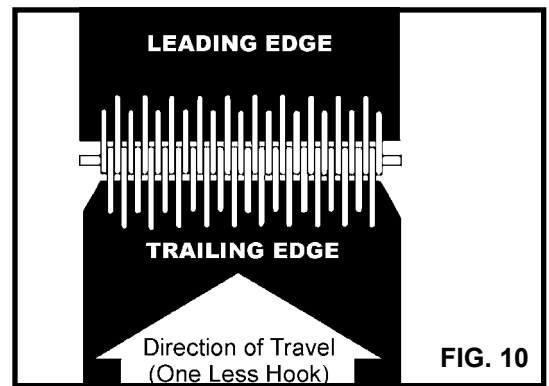

Insertion of hooks into the comb:

1. Insert hooks into the active lacing slots on the comb. Do not place unlaced hooks into the deep slots on the end of the comb.
2. Insert gauge pin into the comb. If using a "D" shaped pin, insert the pin into the comb with the flat side facing up. (See Fig. 11).
3. NOTE: If using the #2-7 combs, with fasteners and gauge pin in place tighten the adjusting side plates by turning the knob on the end of the comb until the side plates are snug against the hook legs. Once snug back the side plates off 1-1/2 turn. No further adjusting will need to be made while lacing the same size hook. (See Fig. 12).
4. If installing hooks into a belt that is wider than the width of the lacer jaws, position comb to

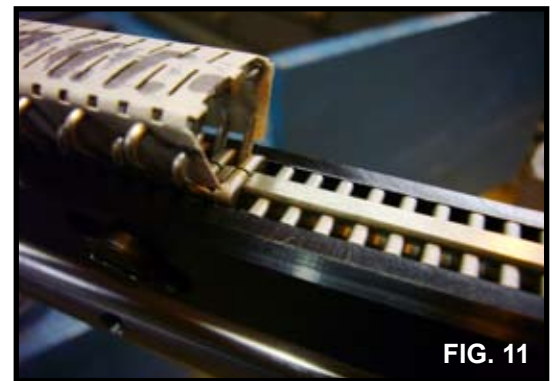

one end of the lacer. This will allow you to install the hooks across the width of the belt in a continuous manner.

Note: If installing hooks into a belt that is narrower than the width of the lacer jaws, position comb so that the hooks are centered in jaws. Failure to do this may cause the machine to apply unequal pressure to the jaws, jamming the machine.

5. If using carded hooks as shown in Figure 13, remove paper. It is easiest to remove the paper completely from the smooth side first (See Fig. 13) and then the opposite side. If using Unibar hooks, remove safety strip (See Fig. 14).
6. Insert belt between hook points, center and hold down perpendicular on comb.

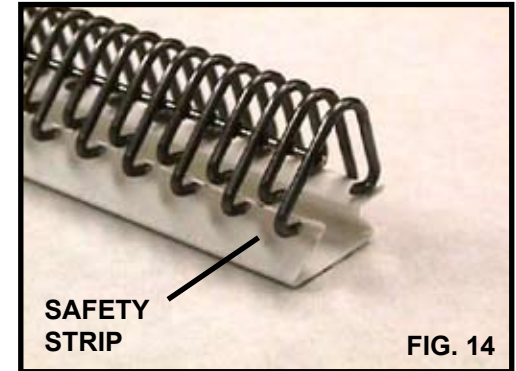
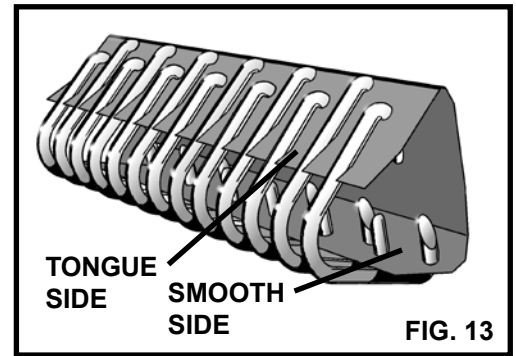

Operating Instructions for Belt Lacers equipped with a SIEMENS TD200 – Control Unit

1. How to Change the Operational Mode:

You may change the operational mode by using the F1 – F7 functional keys. The preferred operational mode can be selected by pushing one of the functional keys.

The lacing machine is supplied with the following pre-settings:

F1,	F5,	F6, and	F7		
	Pressing Mode				
	Pressure: 75 bar	Holding Time: 1 sec		Temperature: 25° C	
F2	Pressing Mode				
	Pressure: 300 bar	Holding Time: 5 sec		Temperature: 25° C	
F3	Pressing Mode				
	Pressure: 400 bar	Holding Time : 5 sec		Temperature: 25° C	
F4	Pressing Mode				
	Pressure: 500 bar	Holding Time : 5 sec		Temperature: 25° C	
F8	Switches Temperature °C to °F and Pressure bar to PSI.				

Note: We have used the pre-setting only for reference. You will have to change the settings according to your belt material, fasteners selected and belt width to be laced.

2. How to Change the Settings for Pressure, Temperature and Holding Time:

The settings of the F1 – F7 keys can be changed as follows:

Select the mode to be changed (F1 – F7). Then press the ▼ key till it arrives at the setting to be changed (pressure, temperature or holding time). To select the value to be changed press the ENTER key once or several times until the value of the required component is reached. To change the value push

▲ to increase the numerical value

▼ to decrease the numerical value

By constantly holding the ▲ or ▼ keys this process will accelerate. When the desired value is reached press ENTER to accept your settings.

Note: If you try to set the values beyond factory-set limits of your belt lacer, then the last setting will be kept and the new value will be ignored (see also no. 3, limiting values for belt lacer).

Follow this same process to change the parameter values for any of the pre-set keys F1-F7. We recommend that you categorize your belts into several groups to have the settings F2 – F4 set as such that you do not need to change the settings too often.

After you are finished setting and entering the values simply press the ▲ key or the footswitch to get back to the first screen.

3. Belt Lacer Parameters (Limiting Values)

Each Belt Lacer will be supplied with the following factory-set limits:

- Minimum Pressure	=>	60 bar
- Maximum Pressure	=>	550 bar
- Maximum Temperature	=>	200°C
- Maximum Holding Time	=>	20 sec
- Pressure Difference Re-Pressing	=>	25 bar

Important Notice: The factory-set values are protected by a password and may only be changed after having consulted the manufacturer. Improper change of these settings may lead to damage of the belt lacer or cause injuries. If changes are made without consulting the manufacturer our warranty and liability are waived.

4. Operation of Heating Mode - Pro 6000 Lacer Only

The jaw-heating is started by pushing the “heat-on” button. As long as the button flashes, the jaws have not yet reached the temperature selected. The selected temperature is reached when the button stops flashing and the light is continuously on.

Lacing Procedures:

1. With comb, belt and hooks in proper position as noted on pages 3 and 4, and with pressure/time/heat setting selected as noted above, press the foot switch. **CAUTION:** Do not place fingers/hands in jaws when depressing the foot switch. Keep loose clothing and jewelry away from jaws. The jaws will remain closed for the amount of time set on the timer switch. After the jaws begin to open it is recommended to momentarily depress the footswitch a second time. This allows the belt to adjust and the hooks to set properly.
2. Inspect the installed splice. A correct pressure is achieved when 1/3-1/2 of the wire diameter is embedded into the belt surface with a "U" shaped loop and the points are just visible from the opposite side of the belt. If the loop has a light-bulb shape to it, reapply the new hooks using a smaller gauge pin and/or with lower pressure. If the hook points are protruding through and curling over, the hook is too large. Reapply using a smaller hook.
3. Increase pressure setting in increments of 50 bars or less until proper setting of the hooks is achieved.
4. Once you have determined the correct lacer settings for your belt, record this data in your log (page 10). Then, with future installations you can refer back to the log and determine the necessary settings for this particular belt.
5. Pull the gauge pin completely out of the comb by pulling it straight, without bending or twisting. Twisting the gauge pin can break the handle off the gauge pin. If necessary, rock the belt back and forth to loosen the gauge pin.

6. Pull the belt straight up, out of the machine. Do not twist the belt as it is removed. If using carded hooks as shown in Figure 17, remove paper at this time.
7. Do not change the pressure setting if you will be making additional splices on the same belt.

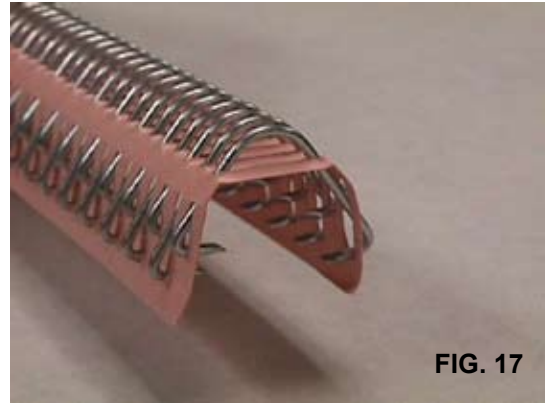

FIG. 17

Continuous Lacing:

If the belt you are lacing is wider than the width of the comb you will need to continuous lace the belt.

1. Lace the entire width of the comb first as noted earlier.
2. Load your remaining hooks into the comb starting with the first active slot next to the extra deep slots. Insert gauge pin through hooks, but not into the extra deep slots.
3. Remove the paper (if applicable).
4. Insert last laced hooks into the extra deep slots (See Fig. 18).
5. Insert gauge pin into the extra deep slots.
6. Install remaining hooks as described above. Repeat the continuous lacing procedure until entire belt width is complete.

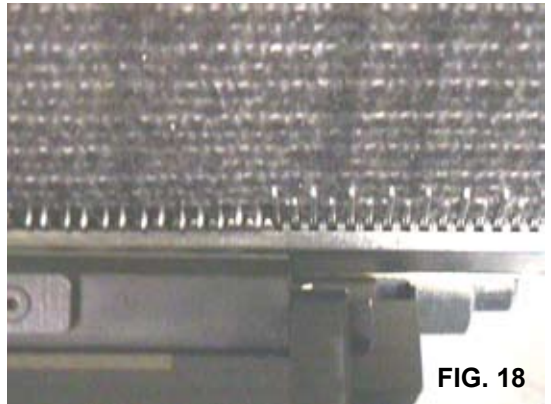

FIG. 18

Miscellaneous:

Adjusting Cam - Adjusting cam can be turned to various settings to control how far the jaws open. The ideal setting is where there is adequate clearance to easily insert hooks into comb and remove paper, yet not excessive clearance. Excessive clearance requires more cycle time as jaws open and close.

Troubleshooting:

1. Machine will not operate.
 - A. Is machine plugged in and power switch on?
 - B. Check power supply. Is there electricity at the outlet?
 - C. Press reset button located inside the electrical box.
 - D. Change fuse located inside the electrical box. A spare fuse is located in the electrical box.
2. Electric pump operates but jaws do not move.
 - A. Is the pressure set above zero?
 - B. Have you checked the hydraulic fluid level and installed the breather cap?
 - C. Are jaws cocked at an angle?
3. Jaws close unevenly.
 - A. Close jaws 3 – 4 times without hooks or a belt inserted between the jaws. This should straighten out the jaws.

Suggested Workbench Setup:

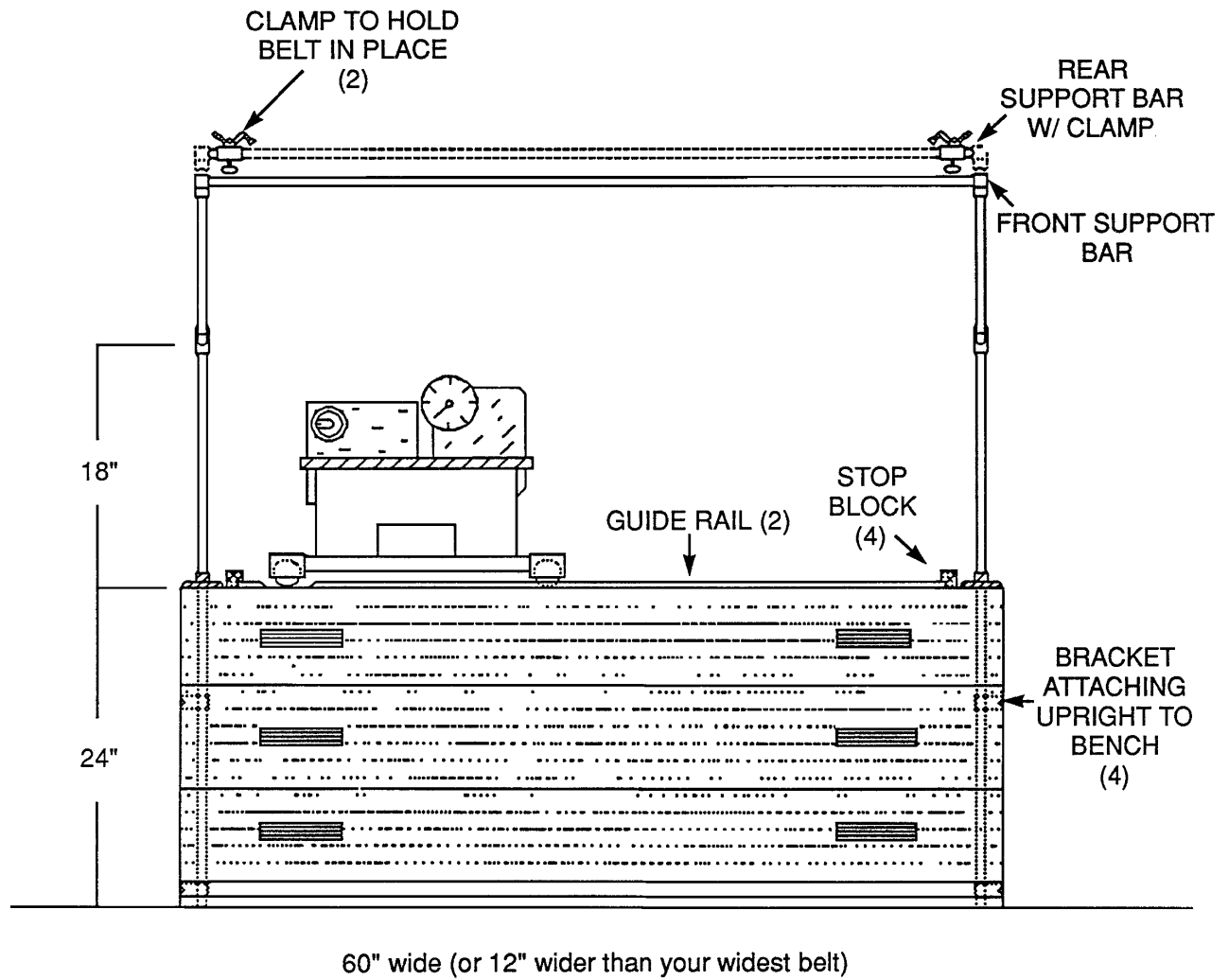

Suggested Workbench Setup:

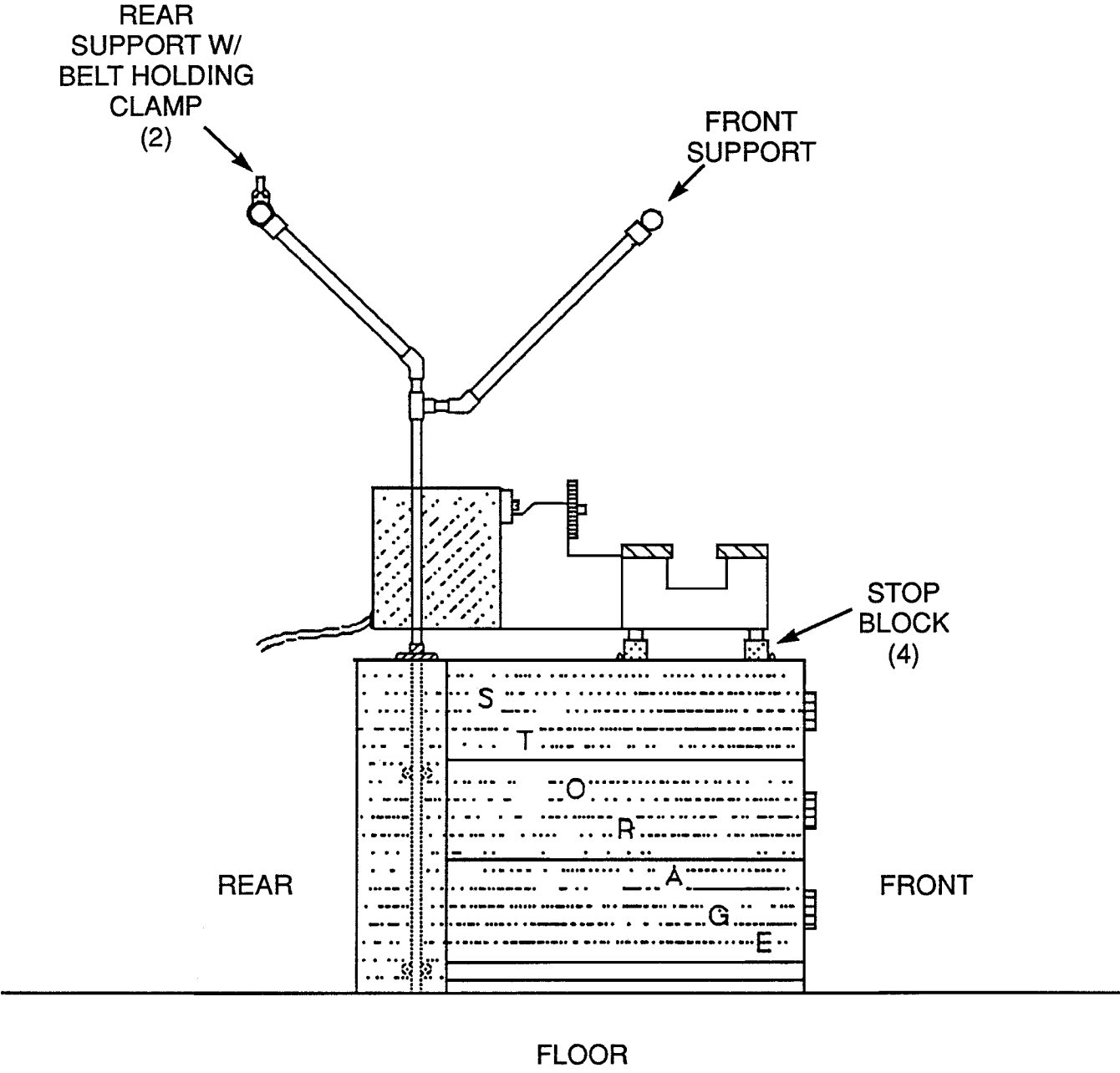

SIDE VIEW

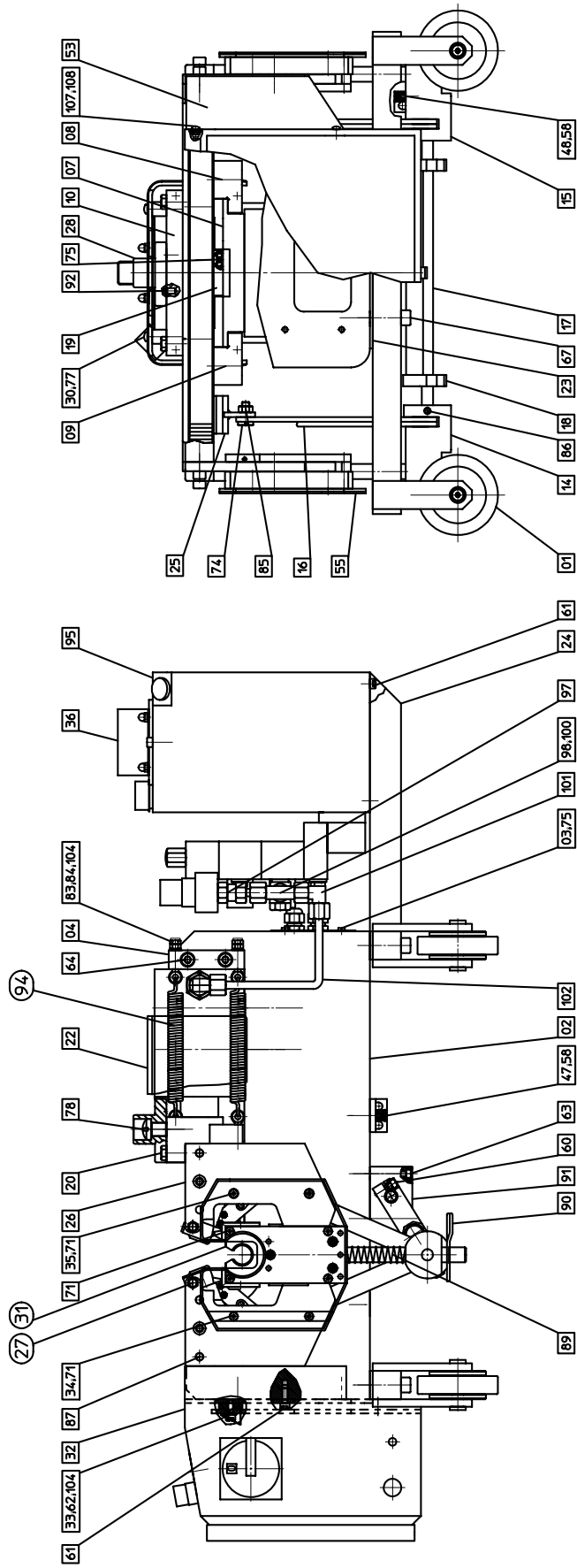

press block assembly 1:1

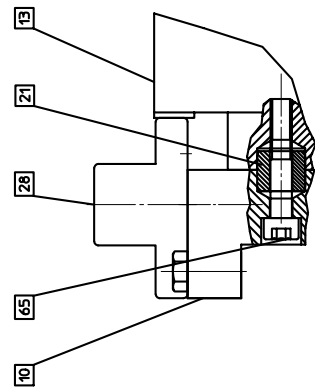

guide plate assembly 1:1

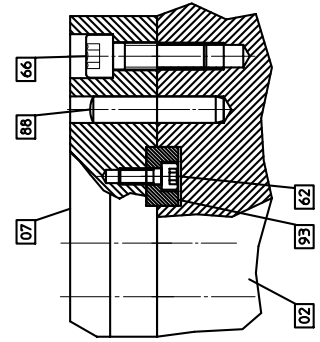

PRO 6000

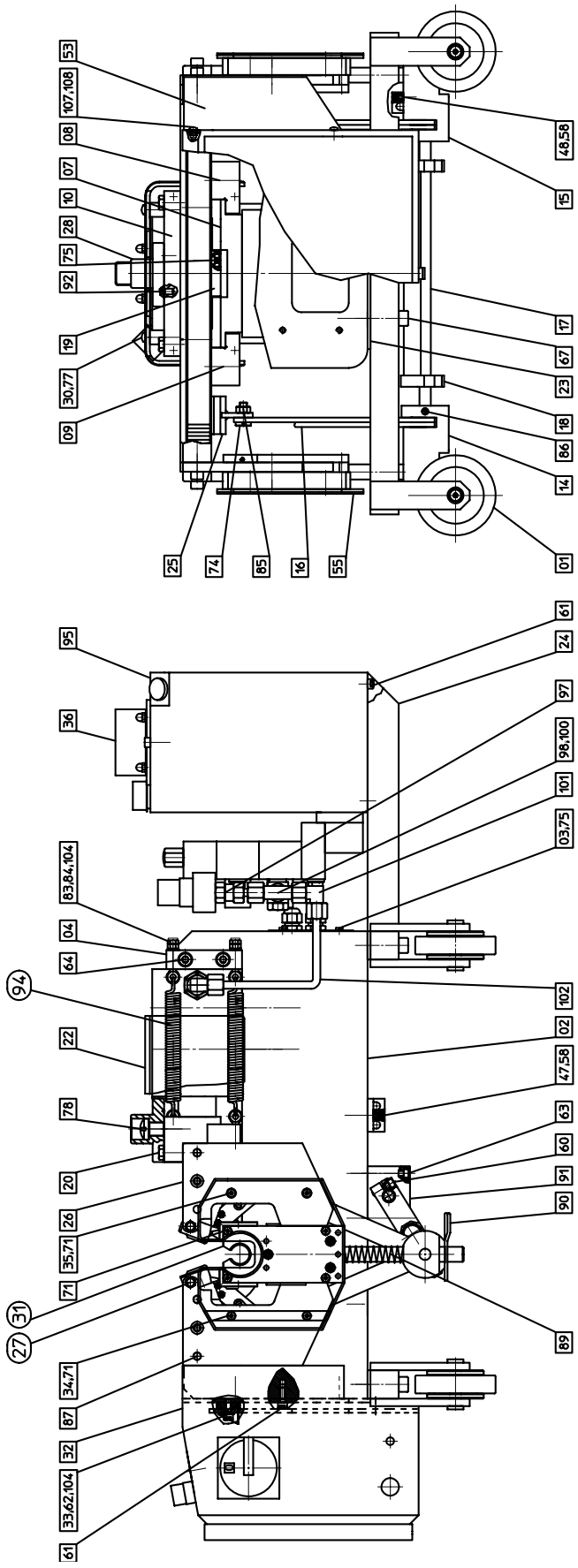

guide plate assembly 1:1

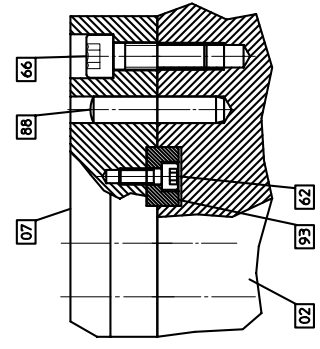

press block assembly 1:1

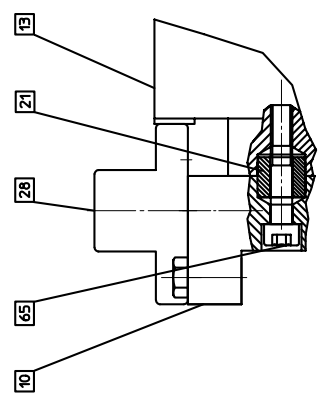

PRO 600

SPARE PART LIST PRO6000

POS	QTY	DESCRIPTION	Draw.-No.
01	2	WHEEL BRACKET	AMK-4T-001
02	1	CAST BODY	AMU-4T-005
03	1	COVER SHEET REAR	AMU-4T-006
04	2	SPRING HOLDER	AMU-4T-007
05	1	SLIDING JAW	AMU-6T-002
06	1	FIXED JAW	AMU-6T-001
07	1	SLIDING JAW GUIDE PLATE	AMU-4T-010
08	1	SLIDING JAW GUIDE TRACK RIGHT	AMU-4T-011
09	1	SLIDING JAW GUIDE TRACK LEFT	AMU-4T-012
10	1	PRESS BLOCK	AMU-4T-013
11	1	PRESSING JAWS LONG	AMU-6T-003
12	1	PRESSING JAWS SHORT	AMU-6T-004
13	1	CYLINDER 200 KN	AMU-4T-016
14	1	SHAFT-END LEFT	AMU-4T-017
15	1	SHAFT-END RIGHT	AMU-4T-030
16	4	ARMS	ARU-2T-020
17	1	ROD	AMU-4T-019
18	1	SHOCK-ABSORBER FORCK	AMU-4T-020
19	2	SLIDING BLOCK	AMU-4T-024

SPARE PART LIST PRO6000

POS	QTY	DESCRIPTION	Draw.-No.
20	2	WASHER HEAD BOLT M8	AMU-4T-025
21	1	BUSHING	AMU-4T-026
22	1	CYLINDER COVER	AMU-4T-027
23	1	SPACER	AMU-4T-028
24	1	PUMP BASE PLATE	AMU-4T-029
25	4	LEVER	ARU-2T-018
26	2	COMP TRACKING PLATE	ARU-2T-021
27	4	WASHER HEAD BOLT M6	ARU-2T-022
28	1	SPACER WASHER	ARU-2T-024
30	2	SPACER	ARU-2T-032
31	2	SLIDING BLOCK GUIDE	ARU-2T-033
32	1	ELECTRIC SWITCH BOX	ARU-2T-047
33	2	SPACER	ARU-2T-048
34	2	SLIDE BAR	ARU-2T-051
35	4	SPACER	ARU-2T-052
36	1	COVER SHEET	HP1000-003
37	1	SLAT, PRESSING JAWS LONG	AMU-6T-005
38	1	SLAT, PRESSING JAWS SHORT	AMU-6T-006
39	1	COVER PLATE	AMU-6T-007
40	1	LEVER	AMU-6T-008

SPARE PART LIST PRO6000

POS	QTY	DESCRIPTION	Draw.-No.
41	1	INSULATION PLATE 1, SLIDING JAWS	AMU-6T-009
42	1	INSULATION PLATE 2, SLIDING JAWS	AMU-6T-010
43	2	INSULATION PLATE 1, SLIDING AND FIXED JAWS	AMU-6T-011
44	2	INSULATION PLATE 2, SLIDING AND FIXED JAWS	AMU-6T-012
45	1	INSULATION PLATE 1, FIXED JAWS	AMU-6T-013
46	1	INSULATION PLATE 2, FIXED JAWS	AMU-6T-014
47	1	DOUBLE CLAMP	ARU-3T-009
48	1	SINGLE CLAMP	ARU-3T-010
49	1	LEVER, PRESSING JAW SHORT	AMU-3T-014
50	1	SUBLEMENTERY LEVER, PRESSING JAW LONG	AMU-3T-015
51	1	SUBLEMENTERY LEVER, PRESSING JAW SHORT	AMU-3T-016
52	1	WIREHOLDER	AMU-3T-017
53	1	COVER RIGHT	AMU-4T-031
54	1	COVER LEFT	AMU-4T-032
55	2	SLIDING BLOCK GUIDE COVER	ARU-2T-050
56	4	HS HC SCREW DIN 912 M3X6	
57	8	HS HC SCREW DIN 912 M3X12	
58	1	HS HC SCREW DIN 912 M4X12	
59	1	HS HC SCREW DIN 912 M4X20	
60	4	HS HC SCREW DIN 912 M5X20	

SPARE PART LIST PRO6000

POS	QTY	DESCRIPTION	Draw.-No.
61	4	HSHC SCREW DIN 912 M6X12	
62	6	HSHC SCREW DIN 912 M6X16	
63	2	HSHC SCREW DIN 912 M6X50	
64	4	HSHC SCREW DIN 912 M8X30	
65	1	HSHC SCREW DIN 912 M8X50	
66	4	HSHC SCREW DIN 912 M10x35	
67	8	HSHC SCREW DIN 912 M10x45	
68	4	HSHC SCREW DIN 912 M12X35	
69	4	HSHC SCREW DIN 912 M16X120	
70	26	HS COUNTERSUNK HS DIN 7991 M3X6	
71	8	HS COUNTERSUNK HS DIN 7991 M4X10	
72	8	HS COUNTERSUNK HS DIN 7991 M4X12	
73	8	HS COUNTERSUNK HS DIN 7991 M5X10	
74	4	SLOTTED PAN HEAD SCREW DIN 923 M8	ARU-2T-027
75	8	HSHC SCREW DIN 7984 M8X20	
76	4	SLOTTED CHEESE HEAD SCREW DIN 84 M4x6	
77	2	BUTTON HEAD SOCKET SCREWS ISO 7380 M5x25	
78	1	BUTTON HEAD SCREWS NLM 754-12	
79	4	EYE BOLTS DIN 444 M6X30	
80	4	EYE BOLTS DIN 444 M6X40	

SPARE PART LIST PRO6000

POS	QTY	DESCRIPTION	Draw.-No.
81	4	HEXAGON HEAD SCREWS DIN 933 M3x6	
82	4	HEXAGON NUT DIN 934 M3	
83	4	HEXAGON NUT DIN 934 M6	
84	4	SELF LOCKING HEXAGON NUT DIN 985 M6	
85	4	SELF LOCKING HEXAGON NUT DIN 985 M8	
86	1	HS SET SCREW CONE POINT DIN 914 M6x10	
87	8	PARALLEL PIN DIN 6325 8M6X22	
88	2	PARALLEL PIN DIN 6325 10M6X50	
89	2	SPRING	ARU-2T-052
90	2	SPRING PIN SIZE 3	
91	1	SHOCK-ABSORBER	
92	2	SPRING PLUNGER	
93	2	NOTCH-STONE NLM 03250-22	
94	4	SPRINGS	
95	1	HYDRAULIC UNIT	
96	1	FOOTPEDAL STEUTE GFSM 1Ö/1S	
97	1	HYDRAULIC FITTING MAVE08SR1/4A3C	
98	1	HYDRAULIC FITTING WH08SRA3C	
99	1	HYDRAULIC FITTING GE08SRA3C	

SPARE PART LIST PRO6000

POS	QTY	DESCRIPTION	Draw.-No.
100	1	HYDRAULIC FITTING ET08SRA3C	
101	2	HYDRAULIC FITTING EW08SA3C	
102	1	HYDRAULIC TUBE 8X1.5MM	
103	1	REDUCTION PIECE RI1/2EDX1/4A3C	
104	6	WASHERS DIN 125-B-6.4 ZINC PLATED	
105	2	CARTRIDGE HEATER	
106	1	RESISTANCE THERMOMETER	
107	4	BUTTON HEAD SOCKET SCREWS ISO 7380 M4x10	
108	4	SELF LOCKING HEXAGON NUT DIN 985 M4	

SPARE PART LIST PRO 600

POS	QTY	DESCRIPTION	Draw.-No.
01	2	WHEEL BRACKET	AMK-4T-001
02	1	CAST BODY	AMU-4T-005
03	1	COVER SHEET REAR	AMU-4T-006
04	2	SPRING HOLDER	AMU-4T-007
05	1	SLIDING JAW	AMU-4T-008
06	1	FIXED JAW	AMU-4T-009
07	1	SLIDING JAW GUIDE PLATE	AMU-4T-010
08	1	SLIDING JAW GUIDE TRACK RIGHT	AMU-4T-011
09	1	SLIDING JAW GUIDE TRACK LEFT	AMU-4T-012
10	1	PRESS BLOCK	AMU-4T-013
11	1	PRESSING JAWS LONG	AMU-4T-014
12	1	PRESSING JAWS SHORT	AMU-4T-015
13	1	CYLINDER 200 KN	AMU-4T-016
14	1	SHAFT-END LEFT	AMU-4T-017
15	1	SHAFT-END RIGHT	AMU-4T-030
16	4	ARMS	ARU-2T-020
17	1	ROD	AMU-4T-019
18	1	SHOCK-ABSORBER FORCK	AMU-4T-020
19	2	SLIDING BLOCK	AMU-4T-024

SPARE PART LIST PRO 600

POS	QTY	DESCRIPTION	Draw.-No.
20	2	WASHER HEAD BOLT M8	AMU-4T-025
21	1	BUSHING	AMU-4T-026
22	1	CYLINDER COVER	AMU-4T-027
23	1	SPACER	AMU-4T-028
24	1	PUMP BASE PLATE	AMU-4T-029
25	4	LEVER	ARU-2T-018
26	2	COMP TRACKING PLATE	ARU-2T-021
27	4	WASHER HEAD BOLT M6	ARU-2T-022
28	1	SPACER WASHER	ARU-2T-024
29	2	SPACER	ARU-2T-032
30	2	SLIDING BLOCK GUIDE	ARU-2T-033
31	1	ELECTRIC SWITCH BOX	ARU-2T-047
32	2	SPACER	ARU-2T-048
33	2	SLIDE BAR	ARU-2T-051
34	4	SPACER	ARU-2T-052
35	1	COVER SHEET	HP1000-003
36	1	COVER RIGHT	AMU-4T-031
37	1	COVER LEFT	AMU-4T-032
38	2	SLIDING BLOCK GUIDE COVER	ARU-2T-050
40	4	HSHC SCREW DIN 912 M5X20	

SPARE PART LIST PRO 600

POS	QTY	DESCRIPTION	Draw.-No.
41	4	HSHC SCREW DIN 912 M6X12	
42	6	HSHC SCREW DIN 912 M6X16	
43	2	HSHC SCREW DIN 912 M6X50	
44	4	HSHC SCREW DIN 912 M8X30	
45	1	HSHC SCREW DIN 912 M8X50	
46	4	HSHC SCREW DIN 912 M10x35	
47	8	HSHC SCREW DIN 912 M10x45	
48	4	HSHC SCREW DIN 912 M12X35	
49	4	HSHC SCREW DIN 912 M16X120	
50	8	HS COUNTERSUNK HS DIN 7991 M4X10	
51	8	HS COUNTERSUNK HS DIN 7991 M4X12	
52	8	HS COUNTERSUNK HS DIN 7991 M5X10	
53	4	SLOTTED PAN HEAD SCREW DIN 923 M8	ARU-2T-027
54	8	HSHC SCREW DIN 7984 M8X20	
55	4	SLOTTED CHEESE HEAD SCREW DIN 84 M4x6	
56	2	BUTTON HEAD SOCKET SCREWS ISO 7380 M5x25	
57	1	BUTTON HEAD SCREWS NLM 754-12	
58	4	EYE BOLTS DIN 444 M6X30	
59	4	EYE BOLTS DIN 444 M6X40	
60	4	HEXAGON NUT DIN 934 M6	

SPARE PART LIST PRO 600

POS	QTY	DESCRIPTION	Draw.-No.
61	4	SELF LOCKING HEXAGON NUT DIN 985 M6	
62	4	SELF LOCKING HEXAGON NUT DIN 985 M8	
63	1	HS SET SCREW CONE POINT DIN 914 M6x10	
64	8	PARALLEL PIN DIN 6325 8M6X22	
65	2	PARALLEL PIN DIN 6325 10M6X50	
66	2	SPRING	ARU-2T-052
67	2	SPRING PIN SIZE 3	
68	1	SHOCK-ABSORBER	
69	2	SPRING PLUNGER	
70	2	NOTCH-STONE NLM 03250-22	
71	4	SPRINGS	
72	1	HYDRAULIC UNIT	
73	1	FOOTPEDAL STEUTE GFSM 1Ö/1S	
75	1	HYDRAULIC FITTING MAV08SR1/4A3C	
76	1	HYDRAULIC FITTING WH08SRA3C	
77	1	HYDRAULIC FITTING GE08SRA3C	
78	1	HYDRAULIC FITTING ET08SRA3C	
79	2	HYDRAULIC FITTING EW08SA3C	
80	1	HYDRAULIC TUBE 8X1.5MM	
81	1	REDUCTION PIECE RI1/2EDX1/4A3C	

SPARE PART LIST PRO 600

POS	QTY	DESCRIPTION	Draw.-No.
82	6	WASHERS DIN 125-B-6.4 ZINC PLATED	
83	4	BUTTON HEAD SOCKET SCREWS ISO 7380 M4x10	
84	4	SELF LOCKING HEXAGON NUT DIN 985 M4	