

**FLEXCO**<sup>®</sup>

---

# Staple Fastener Application Tool

Instruction Manual

---

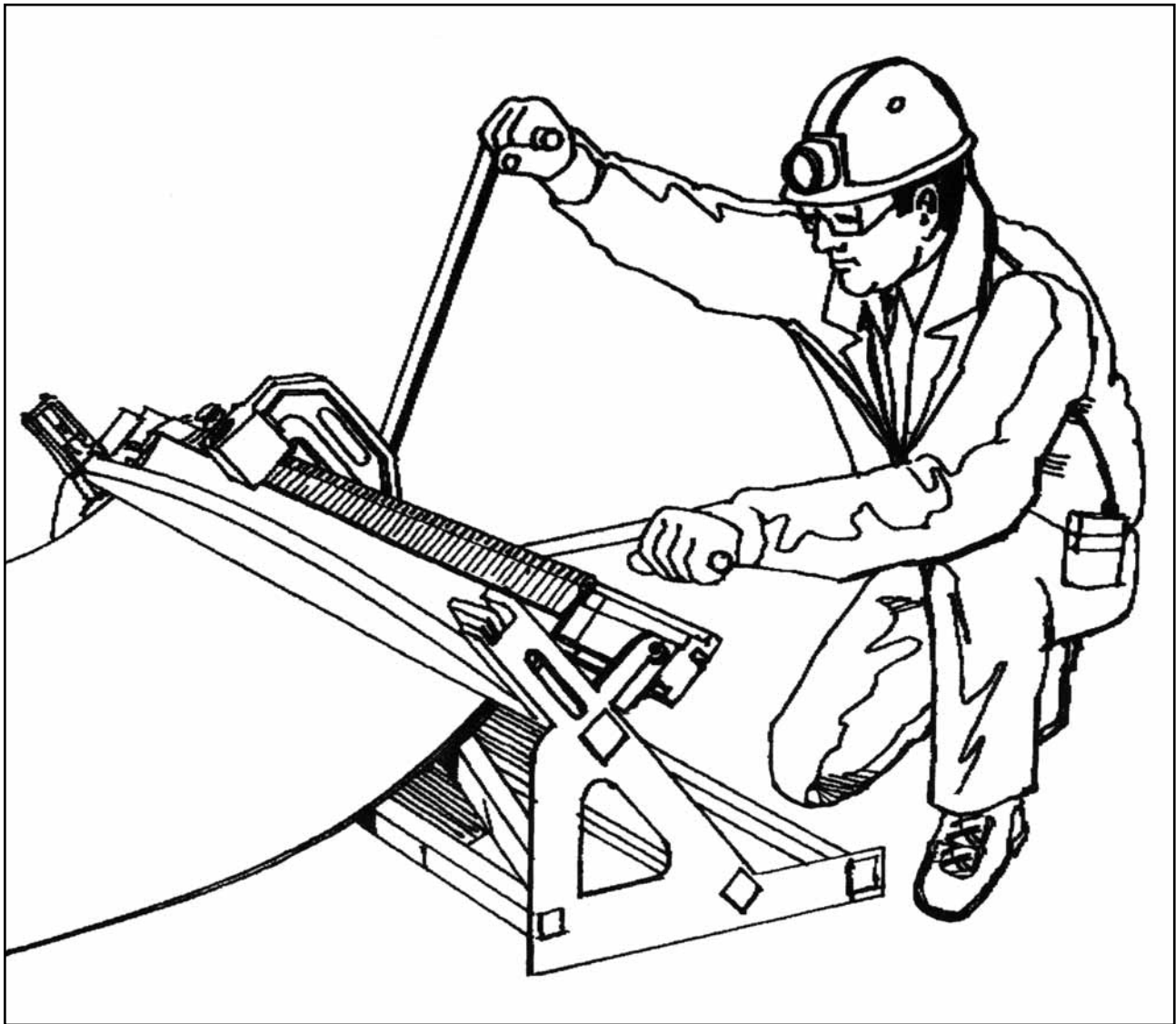



# Table of Contents

How to Square the Belt ..... 4

Preparing and Assembling the Tool..... 5-6

Setting the Belt Thickness Gauge ..... 7

Selecting the Proper Fastener ..... 7

Loading the Fasteners ..... 8

Attaching the Fasteners ..... 9-11



## How to Square a Belt

Squaring your belt ends is a job that requires only a few minutes of your time and offers real paybacks in extending your belt splice life. A splice that is applied on a belt that is properly squared will have the tension evenly distributed across the splice. Properly squared splices are essential to good belt training.

The following steps will help ensure that your belt is properly squared.

**Step 1** Prior to any work on your conveyors, make certain that the power has been turned off and the belt is “locked out”.

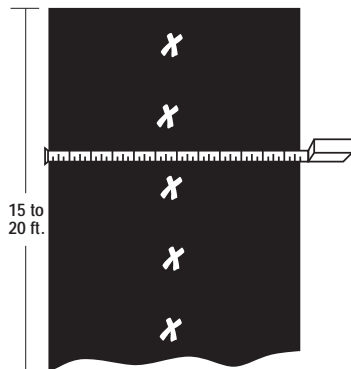

**Step 2** Mark the actual center points in belt width at intervals of 3 to 5 feet, for a distance back from the intended splice area of from 15 to 20 feet.

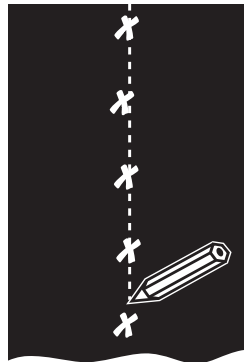

**Step 3** Using either a steel rule or a chalkline, mark the average center line through the points measured from Step 2.



**Step 4** Using a square, draw a line perpendicular to your average center line across the belt width.

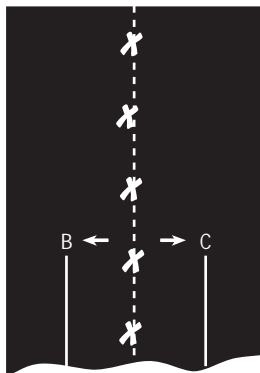

**Step 5** For even greater accuracy in preparing your squaring line and with belts with worn edges, after completion of step three, mark two lines (B&C) equal distance from the center line in the area where you are going to install the splice, running parallel to the center line.

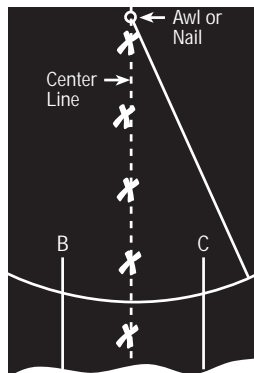

**Step 6** Measure back from the intended splice area a distance equal to approximately three times the belt width and drive a nail or awl at this point on the center line. Using the nail or awl as a pivot point, swing an arc, marking the belt across the full width.

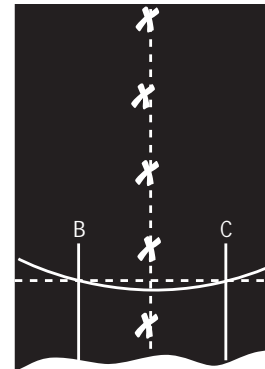

**Step 7** Where this arc intersects the two smaller lines marked parallel to the average belt center, align a steel rule through these points. The resulting line is the true square.

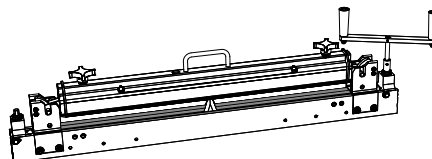

**Step 8** Mark this line and cut your belt at this line using a Flexco Belt Cutter (shown left).

# Flexco® Staple Fastener Application Tool

## Preparing and Assembling the Tool

Examine the tool before applying fasteners. Clean any dirt build-up from the bed rails and lower frame rail. Check the head to make sure the gibs and lower rail slot are free from dirt build-up. Also check for any nicks in the bed that may interfere with the movement of the head. Should any nicks be found, they should be filed off before using the tool. Operate the advance and setting levers to make sure they move freely. Never force these levers as damage to the tool could result. Periodically grease the four fittings (11, Fig. A) located in the head.

Figure A

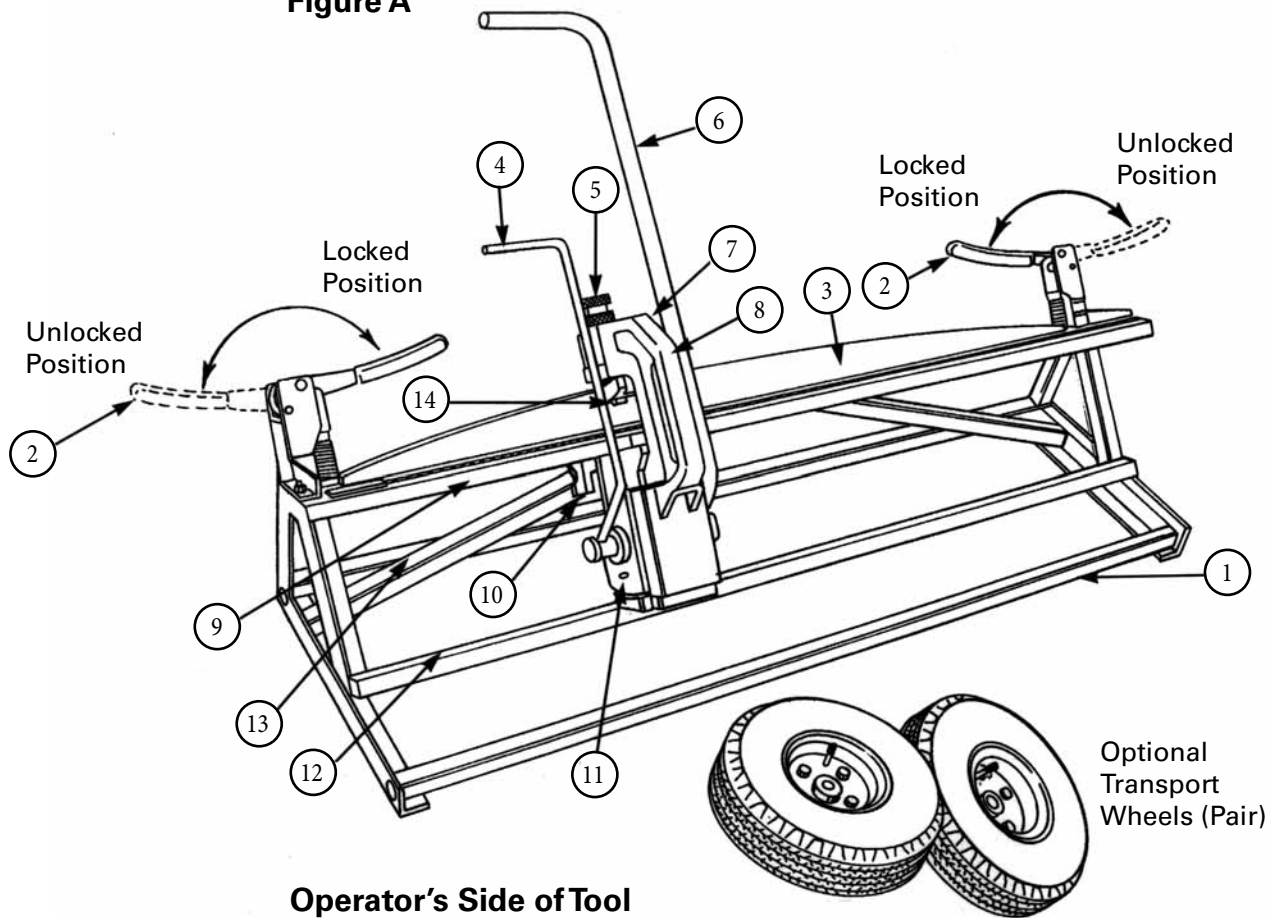

Operator's Side of Tool

- |                         |   |                         |
|-------------------------|---|-------------------------|
| 1. Frame                | 6. Setting Lever                                | 10. Advance Trigger     |
| 2. Clamp Lever (2)      | 7. Belt Thickness Gauge<br>Locking Knob (brass) | 11. Grease Fittings (4) |
| 3. Clamp Hold-Down Bar  | 8. Head   | 12. Lower Rail Slot     |
| 4. Advance Lever        | 9. Bed  | 13. Gibs                |
| 5. Belt Thickness Gauge |   | 14. Anvil               |



# Flexco® Staple Fastener Application Tool

## Preparing and Assembling the Tool (continued)

Attach the head of the tool to the frame by fitting and sliding the gibs located on the head onto the left end of the bed rail. The lower slot in the head will engage the bottom track. Push the head firmly to the right until you hear a “click”. The advance trigger (10, Fig. A) is now engaged in the bed slots. The head can be moved to the right either by continuing to push it firmly or by using the advance lever (4, Fig.A) which indexes the head along the tool bed during application. The head can be moved to the left by depressing the advance trigger while pushing the head to the left.

When installing the head the first time, note that the belt thickness gauge knob (See Fig. D) is shipped in a completely tightened down position. Turn this knob counterclockwise until the belt thickness space is open to at least 1/4”.

**NOTE:** When installing F8 fasteners, it is necessary to remove two screws in the anvil, remove the face plate and anvil insert and reverse it so that the F8 setting faces the operator. Replace the face plate and replace and tighten the screws.

When transporting the tool over any distance, it is recommended that the head be removed and carried separately in the moisture resistant shoulder bag provided with the tool. By using the optional wheels, one person can easily transport the tool alone. (See Fig. B)

If you need to move the tool a short distance or reposition it, it can be carried. Since the head may slide to the right if the left end of the frame is raised higher than the right end, it is suggested that both the advancement and setting levers be moved to their down position (See Fig. C) This will lock the head in place and keep it from sliding.

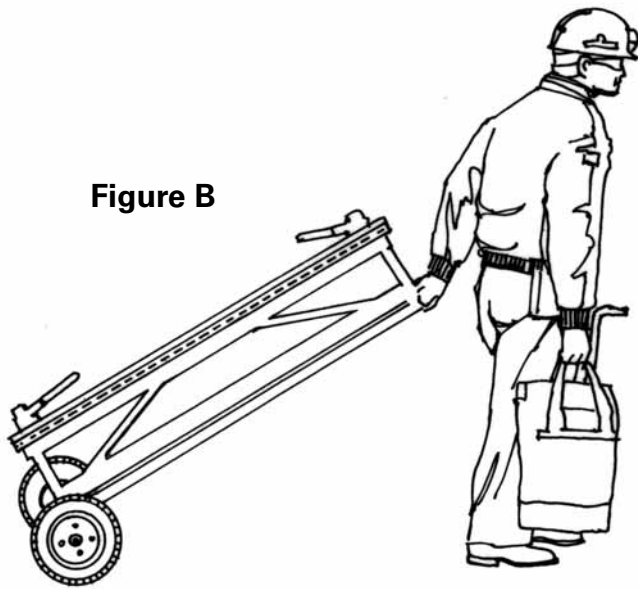

**Figure B**

**Figure C**

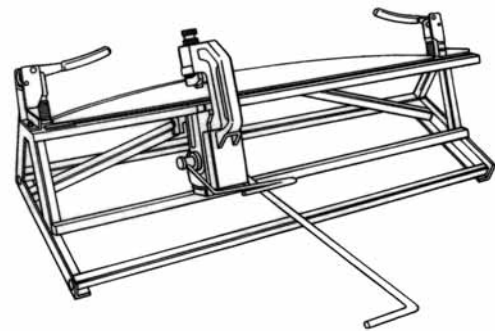

## Setting the Belt Thickness Gauge

Insert the belt end into the belt thickness gauge (See Fig. D) located on top of the head. Adjust the gauge knob until the belt just slides between the knob flange and the top surface of the head. If the belt doesn't fit into the gauge, the gauge is probably set from a previous use. Merely loosen the locking knob and open the gauge by turning the gauge knob counterclockwise several turns. Lock the gauge in place by tightening the locking knob on the side of the head and remove the belt from the gauge. This setting is approximate. A final adjustment may be necessary after the first few fasteners have been installed.

**NOTE:** Back off knob 1/2 turn on hard PVC type belts.

**Figure D**  
**Belt Thickness Gauge**

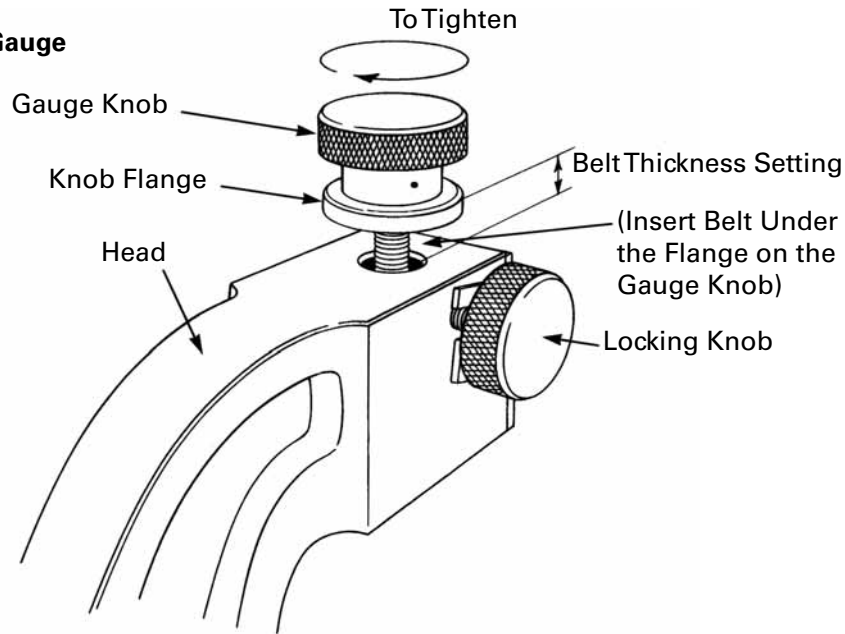

## Selecting the Proper Fastener

Measure the belt's thickness, determine the diameter of the smallest pulley in the system which the belt will wrap at least 90° (including the belt take up and storage unit) and the mechanical fastener rating of the belt. Refer to the table below to select the proper size fastener.

<b>Flexco® Staple-Belt Fastener Selection Chart</b>						
<b>Fastener Sizes</b>	<b>A</b>		<b>B</b>		<b>C</b>	
	<b>For Belts With Mechanical Fastener Ratings Up To</b>		<b>Belt Thickness Range</b>		<b>Recommended Min. Pulley Dia.</b>	
	<b>P. I.W.</b>	<b>kN/m</b>	<b>in.</b>	<b>mm</b>	<b>in.</b>	<b>mm</b>
F8	450	79	3/16-5/16	5-8	6	150
F9	650	114	7/32-11/32	6-9	9	230
F11	650	114	5/16-7/16	8-11	9	230
F12	800	140	11/32-15/32	9-12	12	300
F14	800	140	7/16-9/16	11-14	12	300



## Loading the Fasteners

The fasteners come packaged to provide sufficient fasteners for standard belt widths. You can determine the exact number of fasteners needed for the leading edge of the belt by laying strips of fasteners across the width of the belt. (See Fig. E) Use one less fastener on the trailing edge of the splice to minimize the possibility of the fasteners hanging up during operation. The fasteners should be located approximately 1-1/2 inches (38 mm) equal distance from the edges of the belt. (See Fig. F)

**NOTE:** Do not remove the foam sift-stop™ strips located in the loops of the fastener. This foam strip prevents the sifting of fines through the splice during operation.

**Figure E**  
Laying Fasteners on Belt

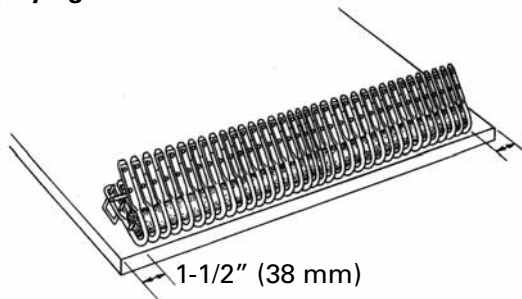

**Figure F**  
Lead and Trailing Ends Matched Up to Show "One Less Fastener" Concept

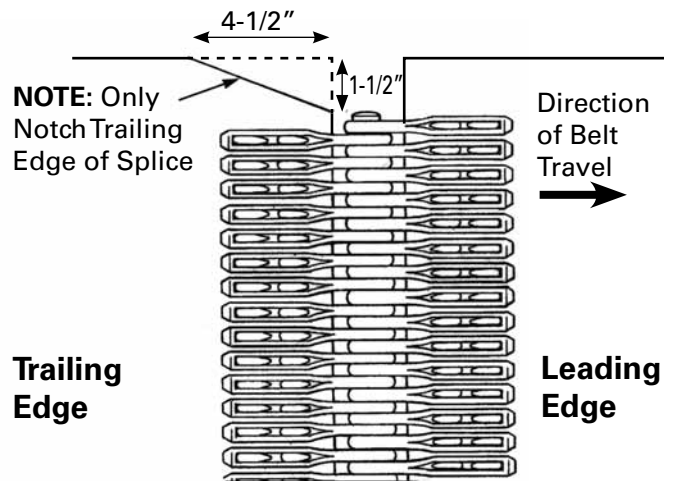

The fasteners are held in position in strip form by a welded cross wire. They can be easily separated into desired lengths by holding the strip in one hand and carefully twisting the strip with the other hand. If a piece of the welded wire remains on the end of the fastener strip you want to use, snip the wire off flush with the end fastener before putting the shortened strip into the bed. Reinsert the sift-stop™ after cutting off the undesired length before applying the fastener to the belt.

Starting with the first available opening from the left end of the tool, insert the fasteners, cross-wire side down, with the open end of the fasteners toward the clamp bar. (See Fig. A) The heads (crowns) of the staple will fit into the slots in the bed. Make sure there are no empty slots between fastener strips. (See Fig. H)

**Figure G**  
Shortening the Fastener Strip

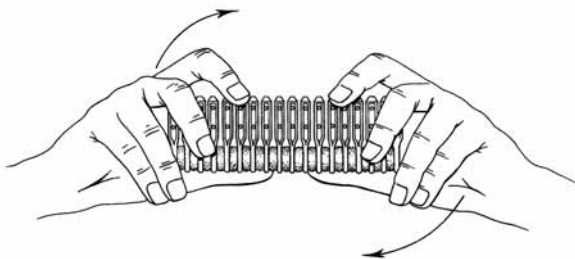

**Figure H**  
Fasteners Placed in Left End of Tool

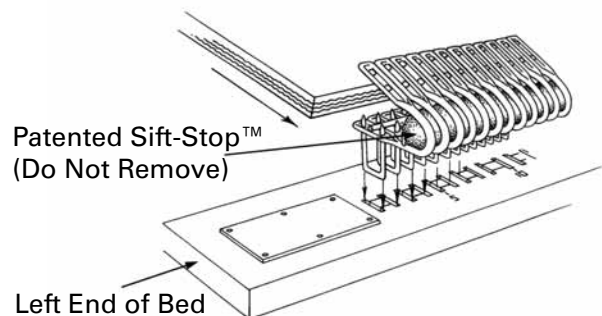

## Attaching the Fasteners

Insert the belt end through the clamp bars (3, Fig. A) and into the fastener. Push the belt end into the fasteners until it is tight against the belt stops which are built into the fasteners. Center the belt so that approximately 1-1/2" of belt extends beyond the fasteners on each edge. (See Fig. F) Secure the belt in this position by pivoting the clamp lever (See Fig. A) into their locked position.

**Figure I**  
Fastener Detail with Callouts and Belt in Place

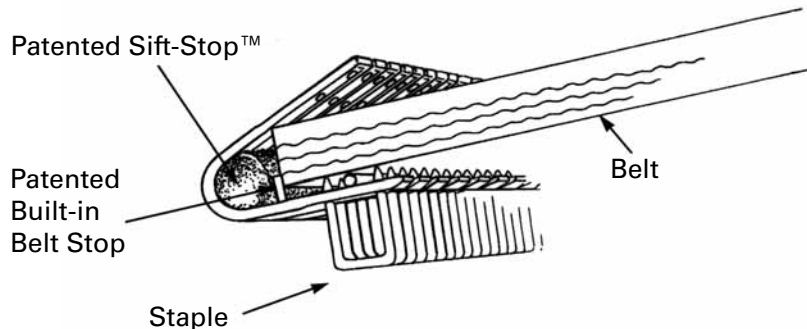

**Figure J**  
Anvil Over First Two Fasteners

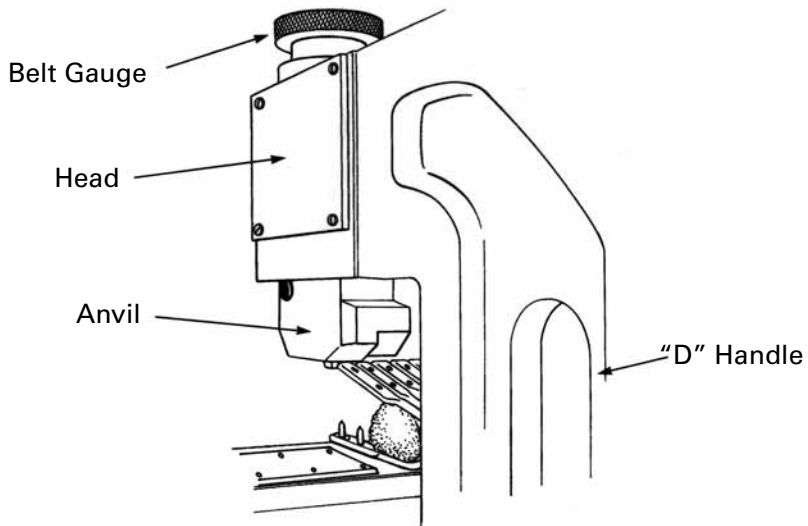

# Flexco® Staple Fastener Application Tool

## Attaching the Fasteners (continued)

Position the head over the first two fasteners by cycling the advance lever until the anvil is in position. With the advance lever in the down position, cycle the setting lever down and up. Cycle the advance lever and then cycle the setting lever.

**NOTE:** To insure that staples are properly set, setting lever must be firmly moved into the “down” position (See Fig. K)

**Figure K**

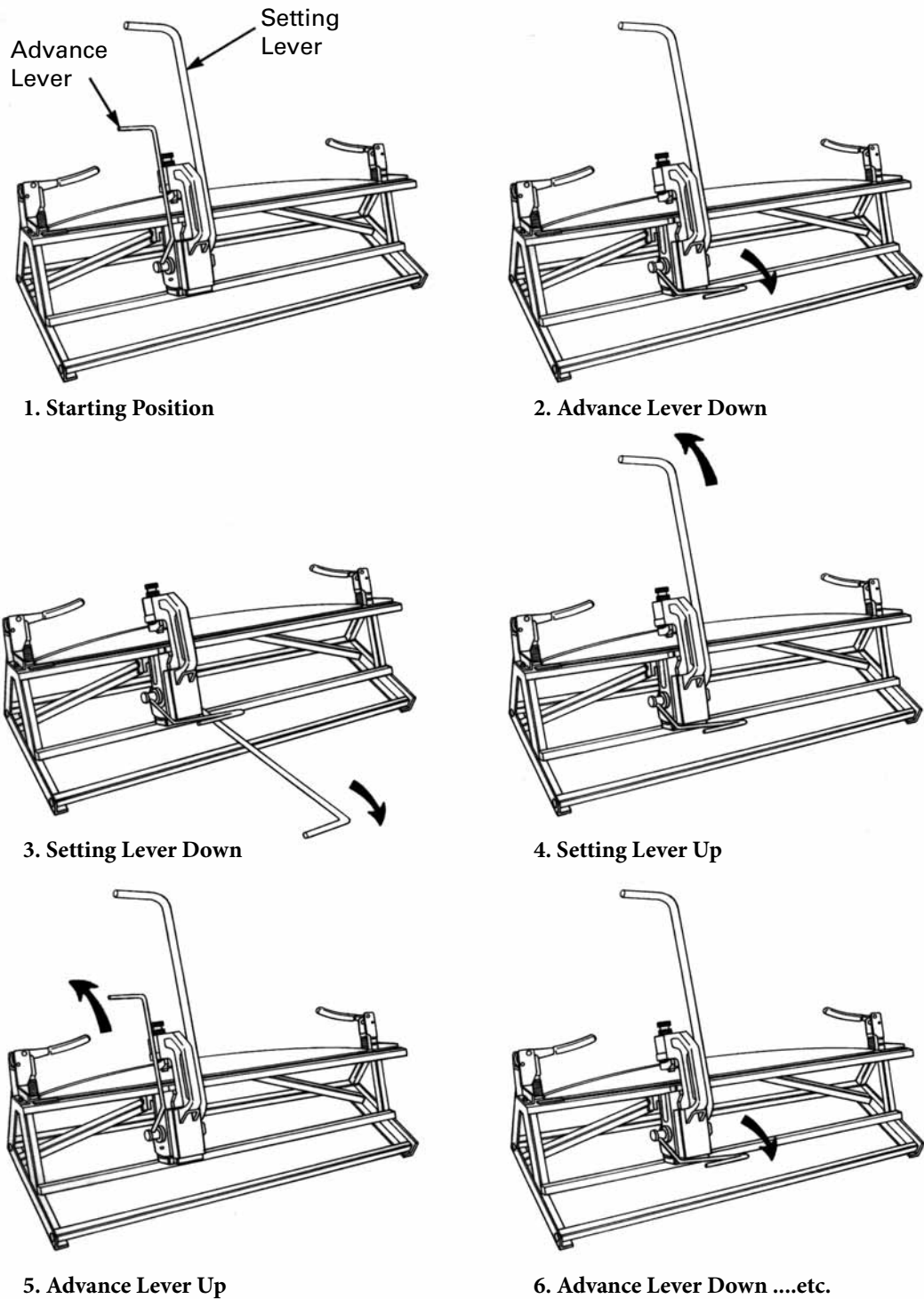

## Attaching the Fasteners (continued)

Examine the first set of fasteners to ensure that the staple legs are set (or flattened) into the pockets of the fastener. The edge of the fastener must be set tight on the belt to prevent hang-ups. To prevent belt ripple, do not over compress fasteners on belt.

Because belt thicknesses may vary across the width of the belt, it is important to examine the fasteners as they are applied. If the back edge of the fasteners is not tight on the belt, adjust the belt thickness gauge by turning it 1/4 turn to the right. If the applied fasteners appear to create a “ripple” in the belt, the fasteners are over tightened. Adjust the belt thickness gauge by turning the gauge knob to the left, or counterclockwise.

Continue to cycle the advance lever and then the setting lever until all of the fasteners have been applied.

Repeat the application procedure on the opposite belt end. Remember, the trailing end of the belt uses one less fastener. This means that before the pin is inserted, the belt ends must mesh together with the fastener loops of the leading end positioned on the outside edges of the belt. (See Fig. D) in the belt ends, insert the hinge pin, and notch the trailing belt edge as shown in Fig. D.

Mark the splice date on the belt using the BT-1 Belt Identification Tool and record it in your belt maintenance record.

**Figure L**  
**Correct Setting of Fastener**

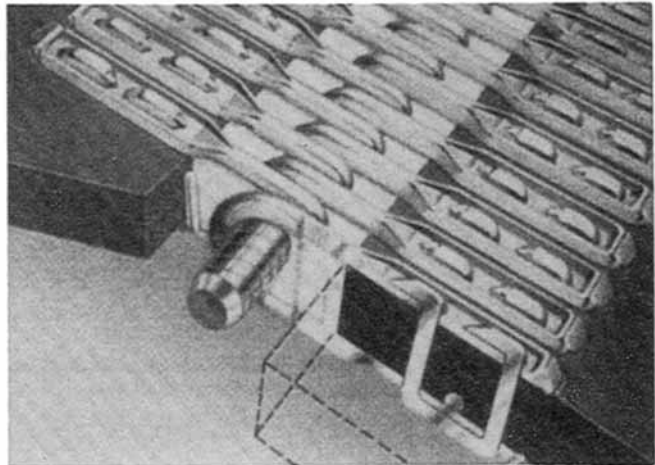

## **WARRANTY**

The Flexco® Staple Application Tool is warranted to be free from all defects in material and workmanship for twelve (12) months from the time of sale, unless such defects are due to improper use, improper maintenance or handling, or ordinary wear and tear.

IN NO EVENT WILL FLEXCO BE LIABLE FOR CONSEQUENTIAL OR INCIDENTAL DAMAGES. THE FOREGOING WARRANTY IS IN LIEU OF ANY OTHER WARRANTIES, EXPRESS OR IMPLIED, AND WARRANTIES OF MERCHANTABILITY AND FITNESS FOR A PARTICULAR PURPOSE.



2525 Wisconsin Avenue • Downers Grove, IL 60515-4200 U.S.A.  
Tel: 1-630-971-0150 • Fax: 1-630-971-1180 • E-mail: • Web: [www.flexco.com](http://www.flexco.com)

Australia: 61-2-9680-3322 • China: 86-21-33528388 • England: 44-1274-600-942  
Germany: 49-7428-9406-0 • Mexico: 52-55-5674-5326 • South Africa: 27-11-608-4180

©2009 Flexible Steel Lacing Company. Flexco® is a registered trademark. 01-09. For Reorder: X0331

