

Flex-Lag® Weld-On™ Pulley Lagging

Installation Instructions

WARNING

Follow your company's safety procedures for welding and maintenance.

NOTE: Illustrations show Flex-Lag® *Ceramic* Weld-On™ Pulley Lagging. Instructions are the same for Flex-Lag® *Rubber* Weld-On™ Pulley Lagging.

Equipment Required for Installation:

- Arc Welder (200 amp)
- Welding shield, gloves, and chipping hammer
- 2-4 welding clamps
- Right angle sander/grinder or wire brush
- Rubber or plastic mallet
- Tape measure
- Carpenter's square
- Marking Pen
- 1/8" AWS E7014 or E7018 weld rod or similar, all position, high tensile, fluxed welding rod
- Saw (optional)

Strips Required for Installation:

Strips Required = Pulley Diameter (inches) ÷ 2

Things to Avoid:

- Insufficient weld penetration or skipping weld locations can result in strips breaking loose and damaging conveyor system components.
- Excessive gap, as shown in step 8, can cause belt cleaner performance problems; resulting in damage to belt, mechanical fasteners, and belt cleaners.
- Overheating lagging can cause premature failure and tile loss.

Installation Instructions:

Please read the entire instructions before beginning installation.

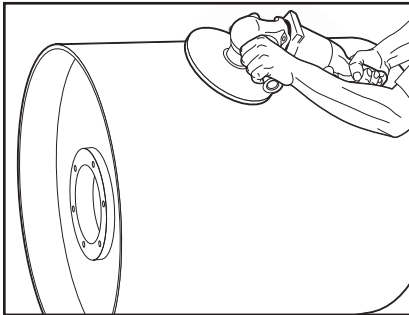

1. Prepare pulley surface for welding. Pulley face should be free of any oil, scale, paint, old lagging, or rust prior to installation. Grind to bare metal. Weld-thru primer or zinc spray can be applied to surface of pulley and welds if additional corrosion protection is desired or for corrosive environments.

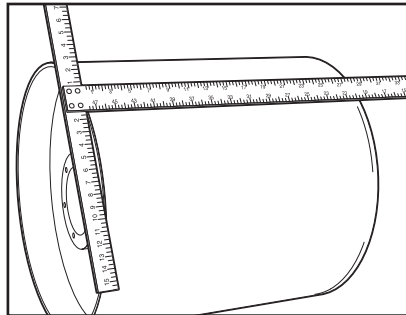

2. Mark a line across the pulley face, parallel to shaft centerline and square to the edge of the pulley. Use carpenter's square against one edge of pulley to serve as a guide. Center first strip to surface of pulley, using line as a guide, and clamp. If lagging strip extends beyond pulley edge by greater than 1/2", excess lagging can be trimmed with a saw. **Note:** See illustration on reverse side for Weld-On™ Ceramic trimming guidelines.

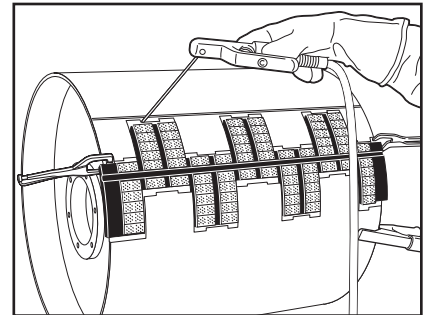

3. Weld lagging into place using cutouts in metal backing plate to locate weld placement. Be sure that backing plate conforms to surface of the pulley prior to welding. If necessary, use a rubber or plastic mallet to conform. Flexco recommends attaching lagging utilizing Shielded Metal Arc Welding (SMAW) commonly referred to as stick welding. Use 1/8" AWS E7014 or similar, all position, high tensile, fluxed, welding rod. Amperage will vary depending on application.

FLEXCO

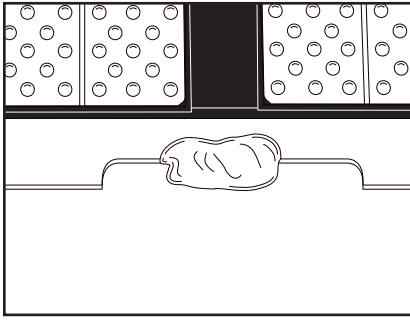

4. Finished weld should be approximately 1" (25 mm) in length and provide good penetration for strength and long life. Weld all locations identified by cutouts. Skipping welds will reduce performance and life.

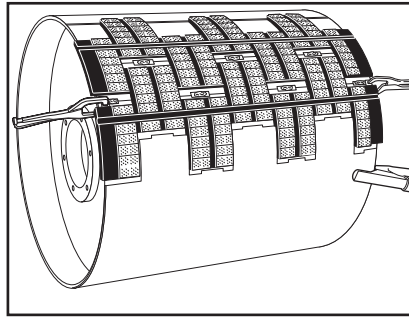

5. Clamp next strip into place making sure it is butted firmly against previous strip. For longer strips, clamp angle iron over strip to secure lagging flush with pulley.

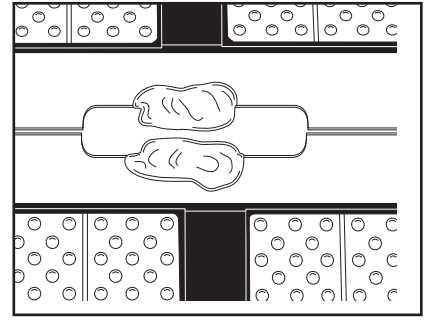

6. Repeat steps 3-5 to attach remaining strips.

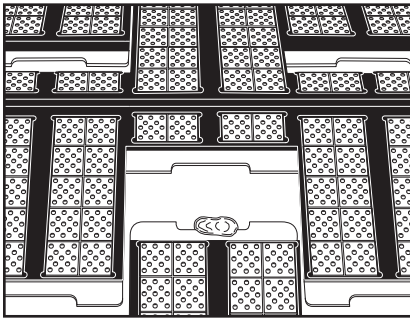

7. Trial fit last 3-4 strips of lagging by clamping into place to determine the final gap length.

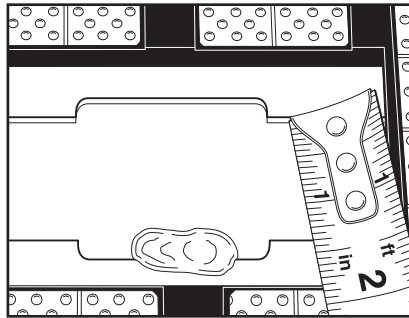

8. If the gap exceeds 1-1/4", distribute the gap evenly by adjusting overlap between last 3-4 strips.

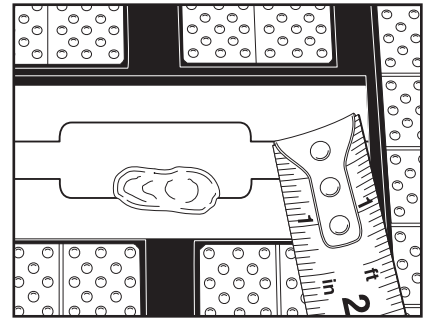

Cutting Guidelines for Ceramic Weld-On™

Option 1: Cut between Sections (3)

- Metal skeleton intact around ceramic lagging

Option 2: Cut between Sub-Sections (4)

- 50% or more of weld cutout remaining on partial strip
- Metal skeleton intact around ceramic lagging
- Do not cut tiles

1. Section
2. Weld Cutout
3. Correct Cut Line Between Sections
4. Correct Cut Line Between Sub-Sections
5. Incorrect Cut Line Example

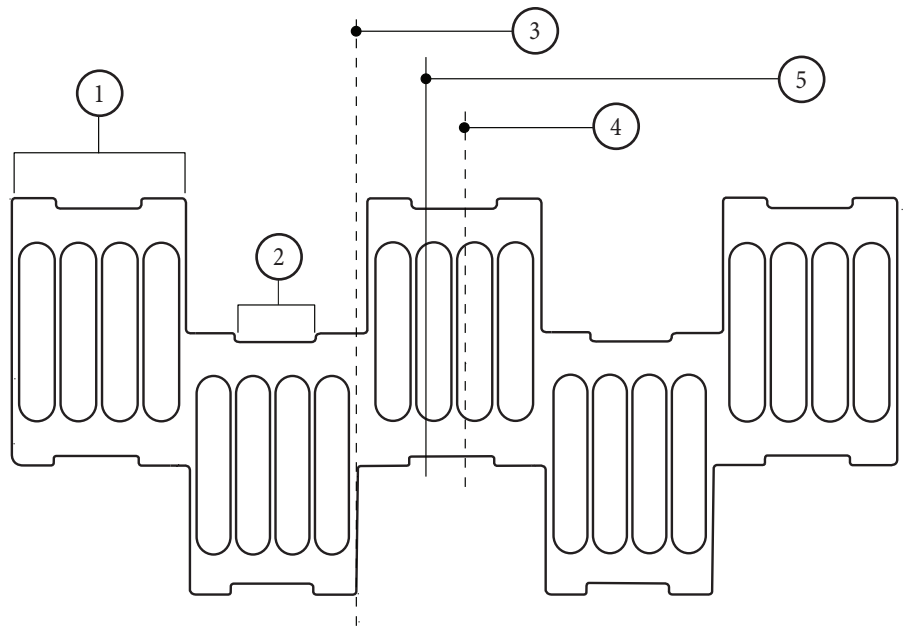

2525 Wisconsin Avenue • Downers Grove, IL 60515-4200 U.S.A.
 Telephone: (630)-971-0150 • Fax: (630)-971-1180 • E-mail: info@flexco.com • Web: www.flexco.com

Australia: 61-2-9680-3322 • China: 86-21-33528388 • England: 44-1274-600-942
 Germany: 49-7428-9406-0 • Mexico: 52-55-5674-5326 • South Africa: 27-11-608-4180

©2009 Flexible Steel Lacing Company. Flex-Lag® is a registered trademark. 09-09. For Reorder: X0760

