

**PHYSICALLY LOCK OUT AND TAG THE CONVEYOR AT THE POWER SOURCE BEFORE YOU BEGIN CLEANER INSTALLATION.**

Installation specs and instructions are based on the assumption that the conveyor is in its working position (angle). If the conveyor angle will be different, the cleaner should be installed per the final position. Call the BCP Helpline 1-800-253-8132 if you need help on determining the proper coordinates.

- 1. Locate the correct pole position.** Measure and determine Dimension A (see instructions above). Find Dimension A on the Pole Location Chart at right and determine Dimensions X, Y and C. Measure out horizontally from the center of the pulley shaft Dim X and mark. From that mark, draw a long vertical line down, then measure and mark Dim Y. This indicates the location of the center of the cleaner pole. Measure and mark both sides. NOTE: If the location is obstructed, use Dim. C and move on an arc from the center of the pulley shaft to find an open position. Dim. C must remain constant to correctly locate the pole (see drawing above). NOTE: For open head installs, first add mounting support materials to the structure.

**Pole Location Chart**

A	X	Y	C
10"	3"	9"	9-1/2"
11"	3-3/4"	9"	9-3/4"
12"	4-3/8"	9"	10"
13"	5-3/8"	9"	10-1/2"
14"	5-7/8"	9"	10-3/4"
15"	6-3/4"	9"	11-1/4"
16"	7-1/8"	9"	11-1/2"
17"	7-7/8"	9"	12"
18"	8-1/4"	9"	12-1/4"
19"	9"	9"	12-3/4"
20"	9-3/8"	9"	13"
21"	10"	9"	13-1/2"
22"	10-3/4"	9"	14"
23"	11-3/8"	9"	14-1/2"
24"	12"	9"	15"
25"	12-5/8"	9"	15-1/2"
26"	13-1/4"	9"	16"
27"	13-7/8"	9"	16-1/2"
28"	14-3/8"	9"	17"
29"	15"	9"	17-1/2"
30"	15-5/8"	9"	18"
31"	16-1/8"	9"	18-1/2"
32"	16-3/4"	9"	19"
33"	17-1/4"	9"	19-1/2"
34"	17-7/8"	9"	20"
35"	18-3/8"	9"	20-1/2"
36"	19"	9"	21"

- 2. Mark and cut the mounting plate holes.** Using the mounting plate template provided in the instruction packet, position the large pole access hole on the chute, aligning the hole notches with the layout lines. Position the keyway toward the pulley. Trace the pole cutout and mounting holes (Fig. 2). Cut the holes on both sides of the chute. NOTE: Hole cutouts are slotted for later adjustment if needed.

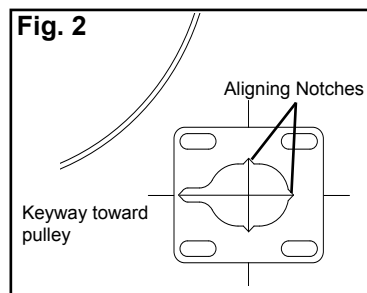

**3. Install the mounting plates.** Bolt the mounting plates to the chute with bolts provided. Center plates on the slotted holes and tighten bolts (Fig. 3).

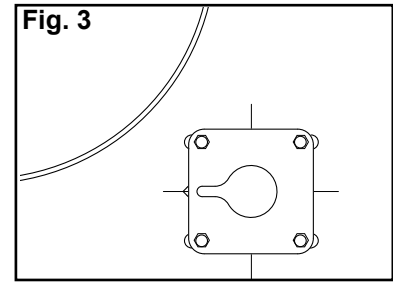

**4. Install the pole.** Remove both blade pins and blade from the pole and insert the pole in through the mounting plates (Fig. 4).

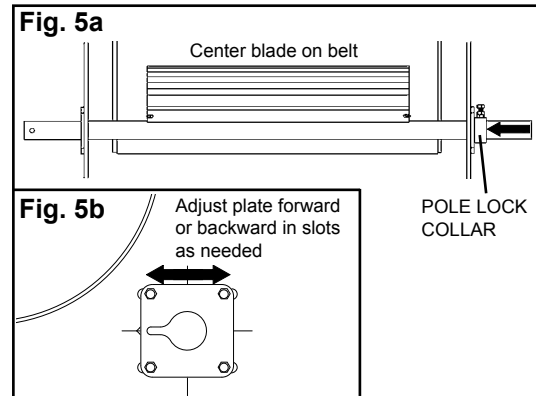
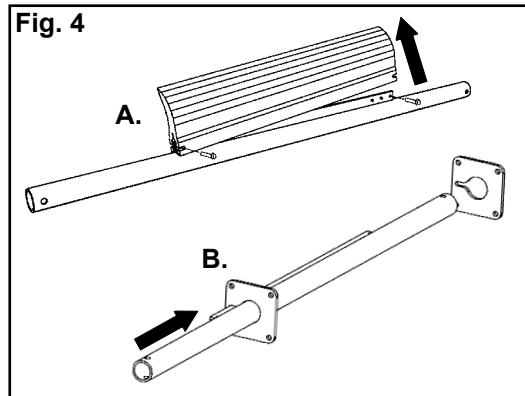

**5. Center the cleaner on the belt and lock in place.** Reinstall the blade with both blade pins. Center the blade on the belt and install the pole lock collar onto the pole (on the end opposite the end to be used for the tensioner), snugly up to the mounting plate (Fig. 5a). Rotate the blade up to the belt and check to insure that the blade is square to the pulley face. If not, loosen a mounting plate on one side and adjust the plate forward or backward to square the blade to the pulley, and retighten the bolts (Fig. 5b).

**NOTE:** The tensioner is assembled for installation on the left side (as you face the head pulley) of the cleaner. If right side installation is desired, some minor reassembly is required. For step-by-step instructions, see the EST Tensioner Card included with the tensioner parts.

**6. Install the tensioner.** Determine desired side and position (Fig. 6a) (the tensioner can be installed in any position 360° around the pole as shown in Fig. 6b) and remove the two mounting plate bolts needed to install the pivot shaft bracket. With the pivot rod inserted through the slotted hole of the torque arm, slide the two components onto the pole together. Using the long bolts provided, fasten the pivot shaft bracket to the mounting plate and tighten (Fig. 6c).

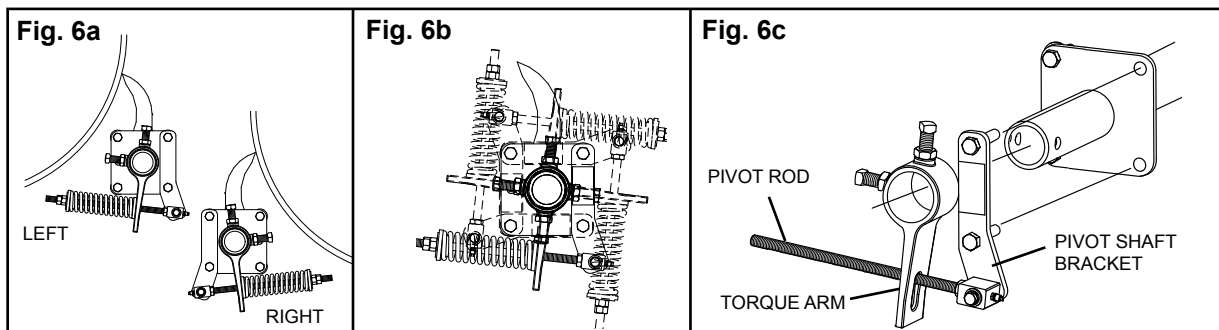

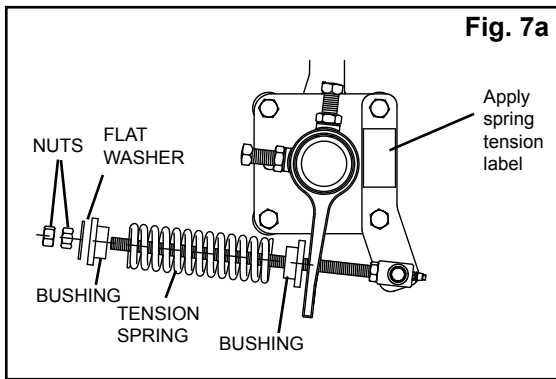

**BLADE TENSION CHART**

BLADE WIDTH	PURPLE SPRING	SILVER SPRING	BLACK SPRING
10"	5 3/4"	6 1/4"	N/A
16"	5 1/4"	6"	N/A
22"	4 3/4"	5 7/8"	N/A
28"	4 1/4"	5 5/8"	N/A
34"	N/A	5 3/8"	5 5/8"
40"	N/A	5 1/8"	5 1/2"
46"	N/A	5"	5 1/4"
52"	N/A	4 3/4"	5 1/8"
58"	N/A	N/A	5"
64"	N/A	N/A	4 3/4"
70"	N/A	N/A	4 5/8"

**7. Set the blade tension.** Assemble the tensioner by sliding the spring with bushings onto the pivot rod, followed by the large washer and two tension nuts (Fig. 7a). Thread nuts onto the pivot rod to expose 1" of the end. Rotate the pole until the blade contacts the pulley. While pulling the torque arm up to the spring, tighten the torque arm to the pole. Set spring length to determined length (Fig. 7b.) Apply the spring tension label (provided in the instruction packet) to the pivot shaft bracket as shown.

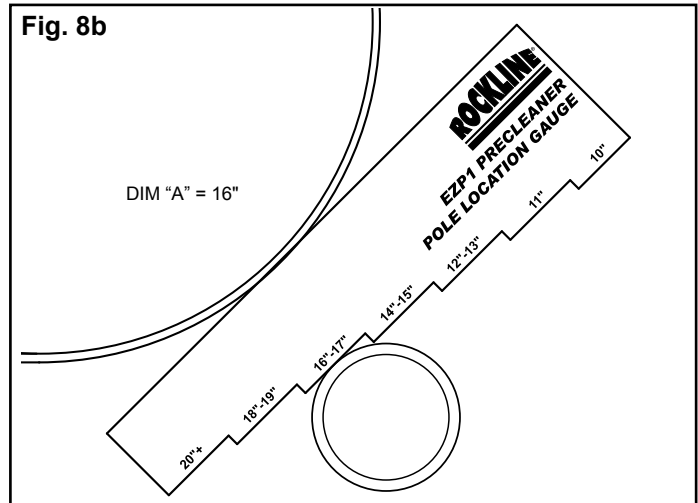
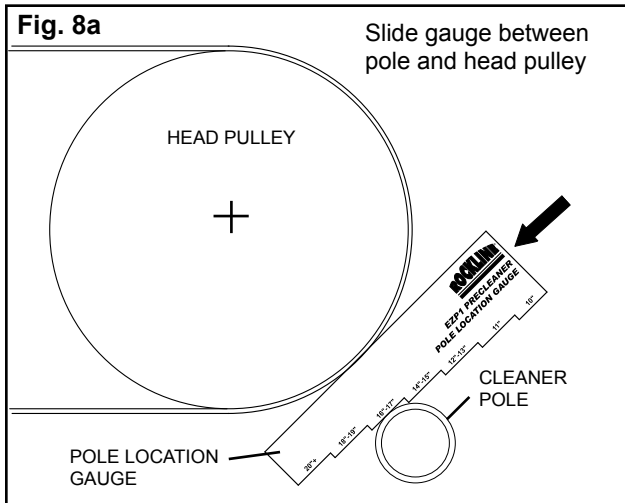

**8. Confirm correct pole location.** After the cleaner is installed, slide the Pole Location Gauge (provided in the instruction packet) between the cleaner pole and the pulley, until it stops at a step (Fig. 8a). Read the flat area where the pole is resting (Fig. 8b). This diameter should be equal to Dim A used in Step 1. NOTE: If the diameter reading on the Pole Location Gauge does not read the same as in Step 1, check the "C" dimension and correct accordingly.

**Test run the cleaner and inspect the performance.** If vibration occurs or more cleaning efficiency is desired, make the necessary tensioning adjustments.



1995 Oak Industrial Dr. NE • Grand Rapids, MI 49505 U.S.A.  
 Telephone: (616)-459-3196 • Fax: (616)-459-4976 • E-mail: info@flexco.com • Web: www.flexco.com

Australia: 61-2-9680-3322 • China: 86-21-33528388 • England: 44-1274-600-942  
 Germany: 49-7428-9406-0 • Mexico: 52-55-5674-5326 • South Africa: 27-11-608-4180

©2008 Flexible Steel Lacing Company. Rockline® is a registered trademark, and ConShear™ is a trademark.  
 U.S. Patent No. D482,508S. 06/08. For Reorder: X1205

