

Flexco® SR™ Rivet Hinged Installation

with the
Hilti DX 460-SR Powder Actuated Tool

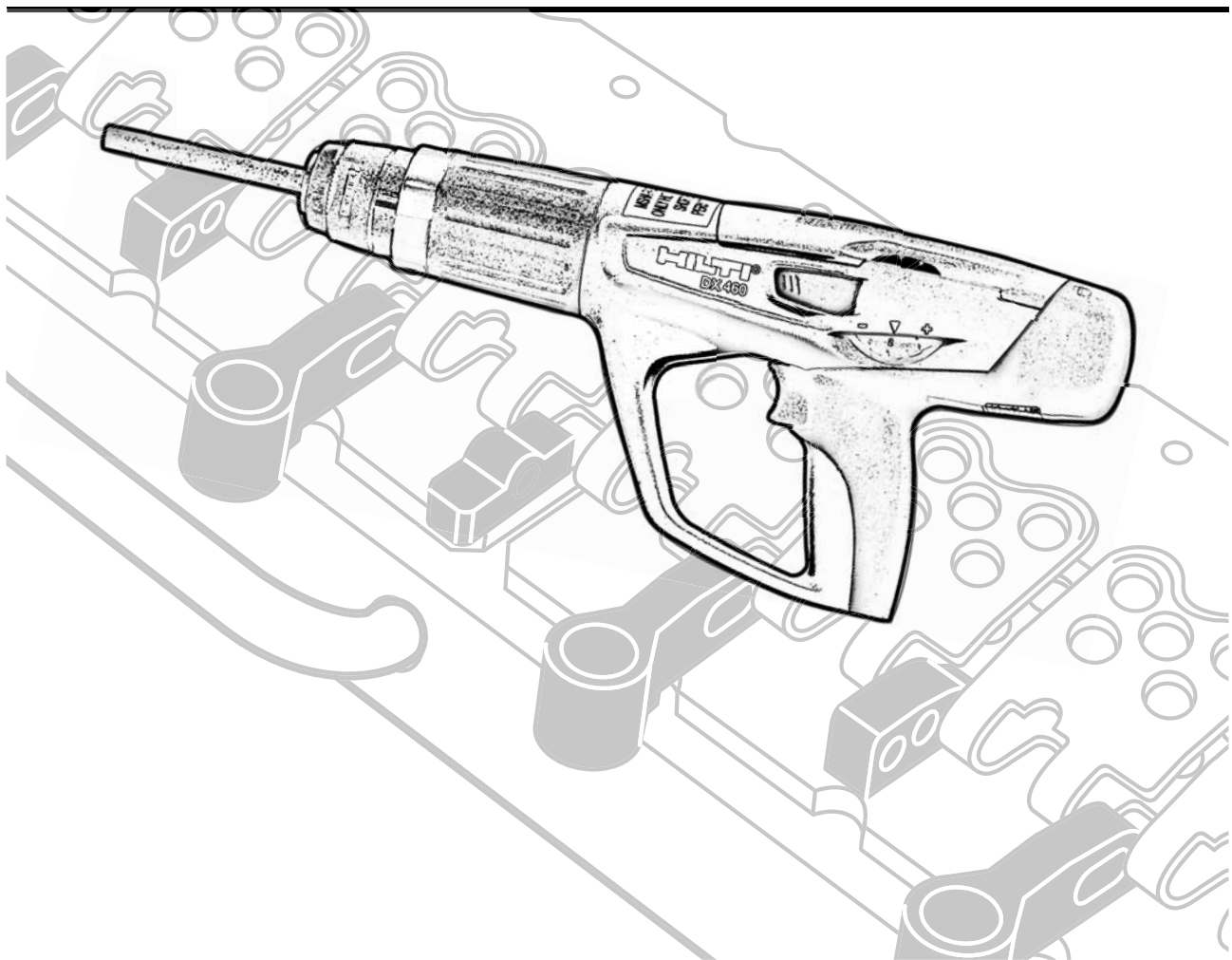

Flexco® SR™ Rivet Installation

with the Hilti DX 460-SR Powder Actuated Tool

General Safety Rules

—Save These Instructions—

Signal words:

“DANGER” indicates an imminently hazardous situation which, if not avoided, will result in death or serious injury. The signal word is limited to the most extreme situations.

“WARNING” indicates a potentially hazardous situation which, if not avoided, could result in death or serious injury.

“CAUTION” indicates a potentially hazardous situation which, if not avoided, may result in minor or moderate injury. It may also be used to alert against unsafe practices.

Safety Symbol



This international safety symbol is used to identify and call attention to specific safety matters.

Safety Information

To Avoid Severe Personal Injury or Property Damage, read carefully and understand the following Safety Precautions.

WARNING

Only HILTI CERTIFIED operators to utilize the HILTI DX 460-SR tool.

Follow all safety requirements listed in the HILTI DX 460-SR operating manual.

The operator and other persons in the immediate vicinity must always wear approved eye protection, a hard hat, and suitable ear protection.

Flexco® SR™ Rivet Installation

with the Hilti DX 460-SR Powder Actuated Tool

Flexco® SR™ Rivet Selection Chart

For use with Flexco® Rivet Hinged Fasteners and Rapid Loader™ Collated Rivets *with washers*

BELT THICKNESS		FOR FASTENER SIZE			
in.	mm	R5	R5-1/2 RAR6LP	R6	
7/32	6				
9/32	7	A			
5/16	8		B	B	
11/32	9		C	C/D	
3/8	10	C			
13/32	10.5		C/D	C/D	D
7/16	11				
15/32	12		D		
1/2	13			E	
17/32	13.5				F
9/16	14				
19/32	15		F*		
5/8	16			G*	
21/32	16.5				
11/16	17				
23/32	18				

* Applies to RAR6LP only

NOTE:

- When installing Flexco Rivet Hinged fasteners with the Hilti DX 460-SR Powder Actuated tool, you must use Rapid Loader™ Collated Rivets *with washers*.
- In areas of overlap, to select the proper rivet, choose the shorter rivet for softer, compressible belts and the longer rivet for hard belts.

Skiving Recommended:

Whenever possible, Flexco recommends skiving the belt in order to countersink mechanical fasteners. Skiving reduces the fastener profile on the belt, resulting in improved fastener/cleaner compatibility and increased fastener service life. To determine proper rivet selection, always measure the belt thickness after skiving. This may require the use of a shorter rivet for increased material savings while maintaining maximum holding ability. In some cases, where belt-operating tension allows for it, a smaller fastener can be applied.

Power Setting and Booster Selection Chart

RIVET SIZE	BOOSTER COLOR	POWER SETTING	
		Steel	Stainless Steel
A	Green	1.5-2.5	2.0-3.0
B	Green	1.5-2.5	2.0-3.0
C	Green	1.5-3.0	2.0-3.5
C/D	Green	1.5-3.0	2.0-3.5
D	Green	2.0-3.5	2.0-3.5
E	Green	2.0-3.5	2.0-3.5
F	Green	2.0-3.5	2.0-3.5
G	Green	2.0-3.5	2.0-3.5
G	Yellow	1.5-3.0	2.0-3.5

Flexco® SR™ Rivet Installation

with the Hilti DX 460-SR Powder Actuated Tool

Troubleshooting

Fault	Possible Cause	Possible Remedies
Rivet is not fully driven into fastener	Driving power is too low	Increase power setting; Use more powerful booster
	Worn or damaged Buffer	Inspect Buffer and replace if worn or damaged
	Worn or damaged Piston	Inspect Piston and replace if worn or damaged Note: Expected life of piston is approximately 20-42" splices
	Hilti DX 460-SR Tool is dirty	Refer Hilti DX 460-SR Tool Operating Instructions for care and maintenance procedures
	Rivet is too long	Use shorter Rivet (Refer Rivet selection chart)
	Piston not reset properly	Turn tool upside-down and "bump" back of tool against a hard surface to reset Piston; Be sure power setting is correct
	Damp Boosters	Use new boosters
Rivet is driven too deep, damaging fastener	Driving power is too high	Reduce power setting; Use less powerful booster
Misfired Rivets (Rivet nail does not pass through bottom plate of fastener)	Rivets do not have Washers	Use only Flexco Rapid Loader Rivets with Washers
	Gauge Pin not used	Use Gauge Pin to properly locate fasteners on application tool
	Applicator tool base rivet locators not positioned properly	Position tool base rivet locators properly
	Nail from previous riveting operation is still in Applicator Tool Base interfering with misfired rivet	Be sure to remove all nails from Base before belt splicing operation
	Rivet previously driven into fastener interfering with misfired rivet	Do not place rivet onto previously driven rivet
Scalloped Edge™ on fastener not compressed into belt	Incorrect riveting sequence	Use recommended rivet sequence (See step 2 Operating Instructions for proper rivet sequence)
	Belt is very hard	Use hammer to set scalloped edge into belt

Flexco® SR™ Rivet Installation

with the Hilti DX 460-SR Powder Actuated Tool

Installation Instructions

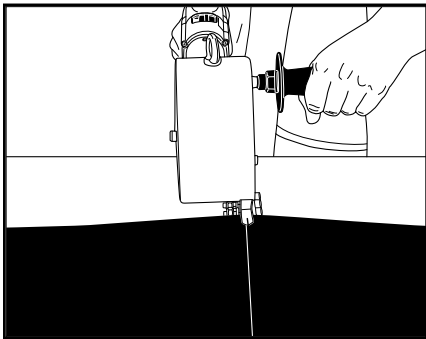

1. Square belt using centerline method. Cut belt 2-3" (50-75 mm) behind old splice using Flexco belt cutting tools. Skive belt when top cover permits.

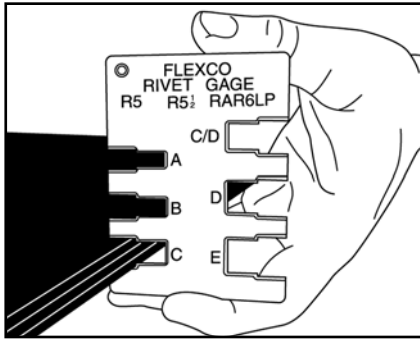

2. Measure belt thickness from cut edge using gauge or tape measure. Select correct size rivets with washers for your belt thickness. When skiving, measure the belt thickness after skiving.

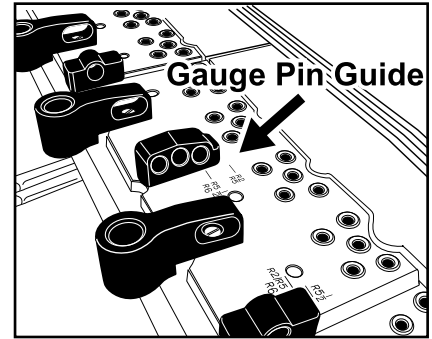

3. Place tool on wooden board the width of the conveyor framework for support when using the MSRT tool. Adjust gauge pin guide to the correct fastener size.

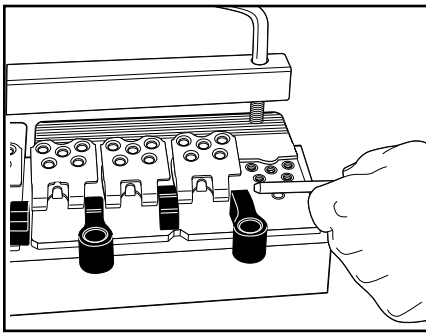

4. Center fastener strip on tool, Flexco stamp facing up. The holes in the fasteners and anvil plate must line up. Insert gauge pin through guides and fastener loops.

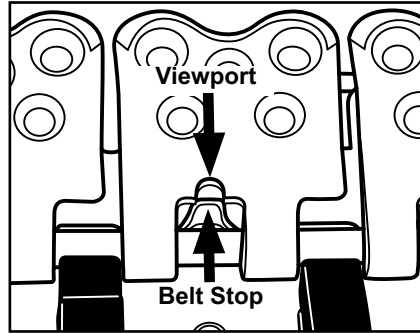

5. Insert belt end into fastener strip; center belt in strip. Look through viewports; belt ends should be tight against belt stops. Tighten hold down bar to secure belt.

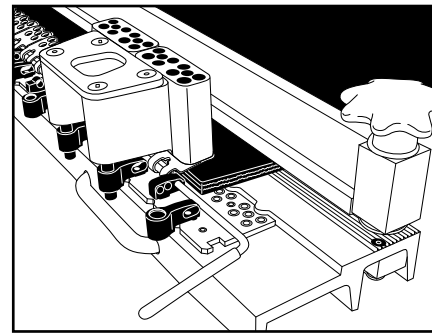

6. Use the steel guide blocks designed for use with the Hilti DX 460-SR Powder Actuated tool. Reduce installation time by adding additional guide blocks across the tool.

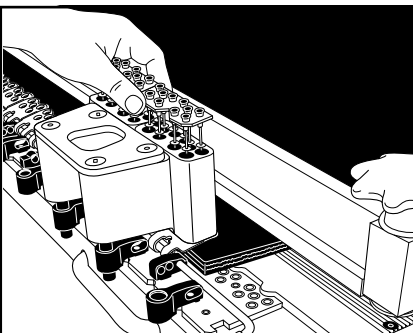

7. Load guide blocks with Rapid Loader™ Collated Rivets with washers.

WARNING: Without washers, misfires will occur. If a shorter strip is needed, break off extra rivets by bending strip at checkpoint.

WARNING: Be sure to remove center rivet from collated strips at anchored end plates.

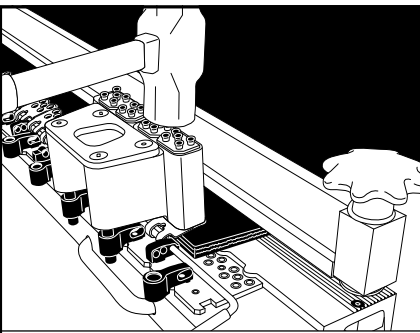

8. Using a hammer, hit the Rapid Loader Collated Rivets to release all rivets from plastic. Remove plastic from guide block and discard. Check the "booster and power lever chart" on page 2 of these instructions.

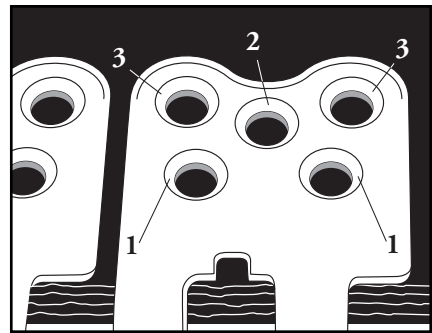

9. Set all fastener top plates with hammer blows. Place metal guide block(s) at either end of the fastener strip. Drive rivets into two holes closest to fastener loops (hinge pin) as shown above. Drive rivet into center then into 2 holes away from fastener loop. While driving rivets keep guide blocks as level as possible to avoid misfires.

Flexco® SR™ Rivet Installation

with the Hilti DX 460-SR Powder Actuated Tool

Installation Instructions

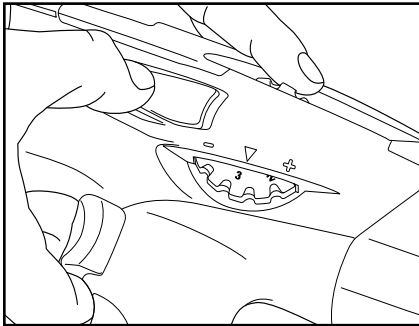

10. Adjusting Power Setting for the Hilti DX 460-SR: Depress lever and rotate power setting dial to recommended power setting. Release lever to lock dial.

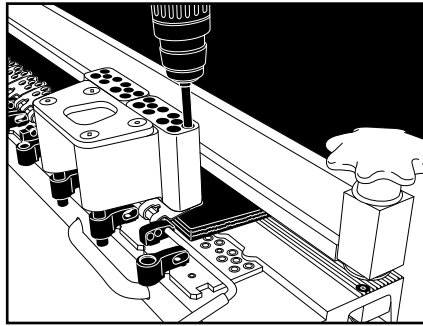

11. Insert the Hilti driver nose directly into the counter bore of the guide block. Press the tool firmly and completely into the guide block. Pull the trigger to drive the rivet. Start with the lowest booster power level and the tool set at the lowest power setting shown on the chart. If rivet is not fully driven into fastener, use hammer to fully drive rivets. Increase power level and repeat until the rivet is properly driven into fastener. Use a more powerful booster if necessary.

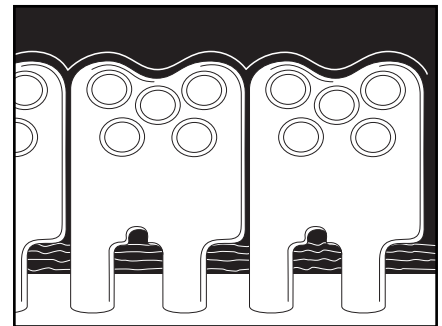

12. Remove guide block(s) and make sure rivets are completely set. Hammer any loose rivets into fasteners to properly set rivets. Hammer scalloped edges of fasteners to set edges into belt. Complete belt splice by moving guide block(s) across the width of the belt and continue driving rivets.

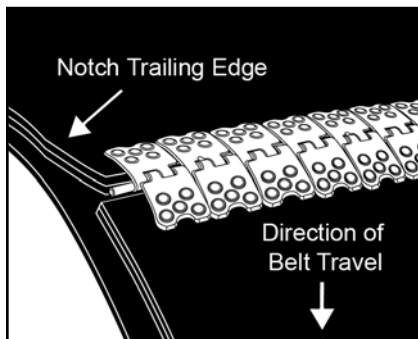

13. Repeat steps 1-11 on other belt end. Bring belt ends together and insert hinge pin. Notch trailing edge of belt only. Splice is complete.



2525 Wisconsin Avenue • Downers Grove, IL 60515-4200 U.S.A.

Telephone: (630)-971-0150 • Fax: (630)-971-1180 • E-mail: info@flexco.com • Web: www.flexco.com

Australia: 61-2-9680-3322 • China: 86-21-33528388 • England: 44-1274-600-942 • Germany: 49-7428-9406-0
India: 91-44-4354-2091 • Mexico: 52-55-5674-5326 • Singapore: 65-6281-7278 • South Africa: 27-11-608-4180

©2011 Flexible Steel Lacing Company. Flexco® is a registered trademark. Hilti® is a registered trademark of Hilti, Inc. 05-11. For Reorder X2189

