

H-Type[®] Precleaner with V-Tips

Installation, Operation and Maintenance Manual

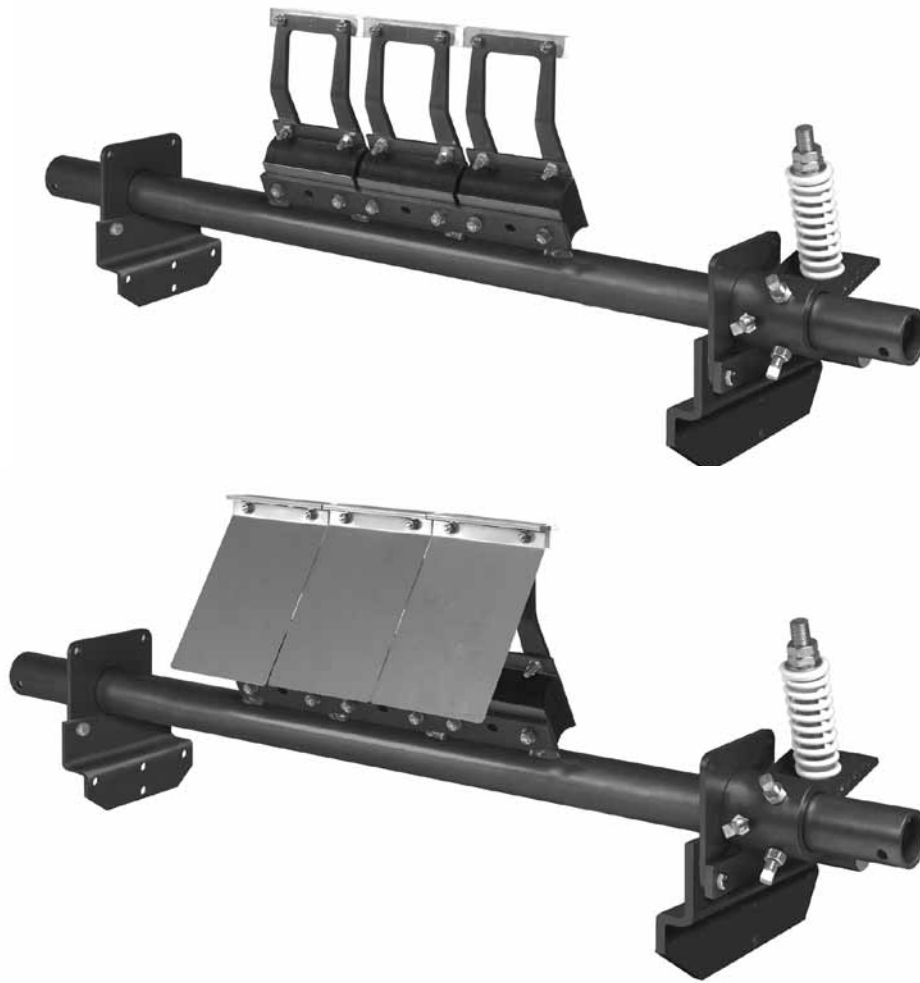

H-Type® Precleaner with V-Tips

Serial Number: _____
Purchase Date: _____
Purchased From: _____
Installation Date: _____

Serial number information can be found on the Serial Number Label included in the Information Packet found in the cleaner carton.

This information will be helpful for any future inquiries or questions about belt cleaner replacement parts, specifications or troubleshooting.

Table of Contents

Section 1 – Important Information	2
1.1 General Introduction	2
1.2 User Benefits	2
1.3 Service Option	2
Section 2 – Safety Considerations and Precautions	3
2.1 Stationary Conveyors	3
2.2 Operating Conveyors	3
Section 3 – Pre-Installation Checks and Options.....	4
3.1 Checklist	4
Section 4 – Installation Instructions.....	5
4.1 Installation Instructions.....	5
4.2 Pole Location Charts	8
4.3 Shimmiing Instructions	9
Section 5 – Pre-Operation Checklist and Testing.....	10
5.1 Pre-Op Checklist	10
5.2 Test Run the Conveyor	10
Section 6 – Maintenance	11
6.1 New Installation Inspection	11
6.2 Routine Visual Inspection	11
6.3 Routine Physical Inspection.....	11
6.4 Blade Replacement Instructions.....	12
6.5 Maintenance Log.....	14
6.6 Cleaner Maintenance Checklist.....	15
Section 7 – Troubleshooting	16
Section 8 – Specs and CAD Drawings.....	17
8.1 Specifications and Guidelines	17
8.2 CAD Drawings.....	18
Section 9 – Replacement Parts List.....	23
Section 10 – Other Flexco Conveyor Products.....	24

Section 1 – Important Information

1.1 General Introduction

We at Flexco are very pleased that you have selected an H-Type Precleaner with V-Tips for your conveyor system.

This manual will help you to understand the operation of this product and assist you in making it work up to its maximum efficiency over its lifetime of service.

It is essential for safe and efficient operation that the information and guidelines presented be properly understood and implemented. This manual will provide safety precautions, installation instructions, maintenance procedures and troubleshooting tips.

If, however, you have any questions or problems that are not covered, please visit our web site or contact our Customer Service Department:

Web site: Flexco.com

Customer Service: USA: 1-800-541-8028

Australia: 61-2-9680-3322 • China: 86-21-33528388

England: 44-1274-600-942 • Germany: 49-7428-9406-0

India: 91-44-4354-2091 • Mexico: 52-55-5674-5326

Singapore: 65-6281-7278 • South Africa: 27-11-608-4180

Please read this manual thoroughly and pass it on to any others who will be directly responsible for installation, operation and maintenance of this cleaner. While we have tried to make the installation and service tasks as easy and simple as possible, **it does however require correct installation and regular inspections and adjustments to maintain top working condition.**

1.2 User Benefits

Correct installation and regular maintenance will provide the following benefits for your operation:

- Reduced conveyor downtime
- Reduced man-hour labor
- Lower maintenance budget costs
- Increased service life for the belt cleaner and other conveyor components

1.3 Service Option

The H-Type Precleaner with V-Tips is designed to be easily installed and serviced by your on-site personnel. However, if you would prefer complete turn-key factory service, please contact your local Flexco Field Representative.

Section 2 – Safety Considerations and Precautions

Before installing and operating the H-Type Precleaner with V-Tips, it is important to review and understand the following safety information.

There are set-up, maintenance and operational activities involving both **stationary** and **operating** conveyors. Each case has a safety protocol.

2.1 Stationary Conveyors

The following activities are performed on stationary conveyors:

- Installation
- Blade replacement
- Repairs
- Tension adjustments
- Cleaning

DANGER

It is imperative that OSHA/MSHA Lockout/Tagout (LOTO) regulations, 9 CFR 1910.147, be followed before undertaking the preceding activities. Failure to use LOTO exposes workers to uncontrolled behavior of the belt cleaner caused by movement of the conveyor belt. Severe injury or death can result.

Before working:

- Lockout/Tagout the conveyor power source
- Disengage any takeups
- Clear the conveyor belt or clamp securely in place

WARNING

Use Personal Protective Equipment (PPE):

- Safety eyewear
- Hardhats
- Safety footwear

Close quarters, springs and heavy components create a worksite that compromises a worker's eyes, feet and skull.

PPE must be worn to control the foreseeable hazards associated with conveyor belt cleaners. Serious injuries can be avoided.

2.2 Operating Conveyors

There are two routine tasks that must be performed while the conveyor is running:

- Inspection of the cleaning performance
- Dynamic troubleshooting

DANGER

Every belt cleaner is an in-running nip hazard. Never touch or prod an operating cleaner. Cleaner hazards cause instantaneous amputation and entrapment.

WARNING

Belt cleaners can become projectile hazards. Stay as far from the cleaner as practical and use safety eyewear and headgear. Missiles can inflict serious injury.

WARNING

Never adjust anything on an operating cleaner. Unforeseeable belt projections and tears can catch on cleaners and cause violent movements of the cleaner structure. Flailing hardware can cause serious injury or death.

Section 3 – Pre-installation Checks and Options

3.1 Checklist

- Check that the cleaner size is correct for the beltline width
- Check the belt cleaner carton and make sure all the parts are included
- Review the “Tools Needed” list on the top of the installation instructions
- Check the conveyor site:
 - Will the cleaner be installed on a chute
 - Is the install on an open head pulley requiring mounting structure
 - Are there obstructions that may require cleaner location adjustments

Section 4 – Installation Instructions

4.1 H-Type® Precleaner with V-Tips or Protected V-Tips

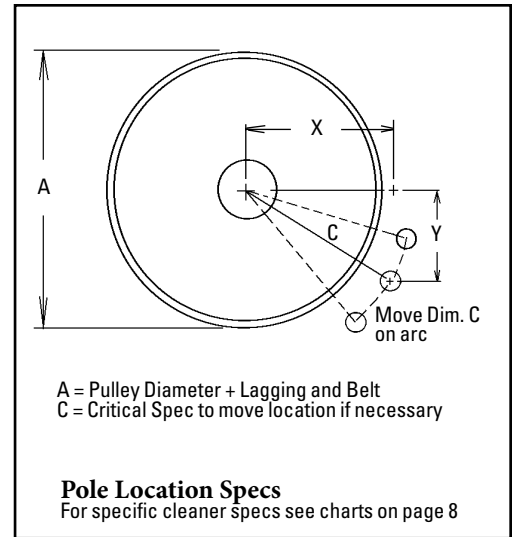
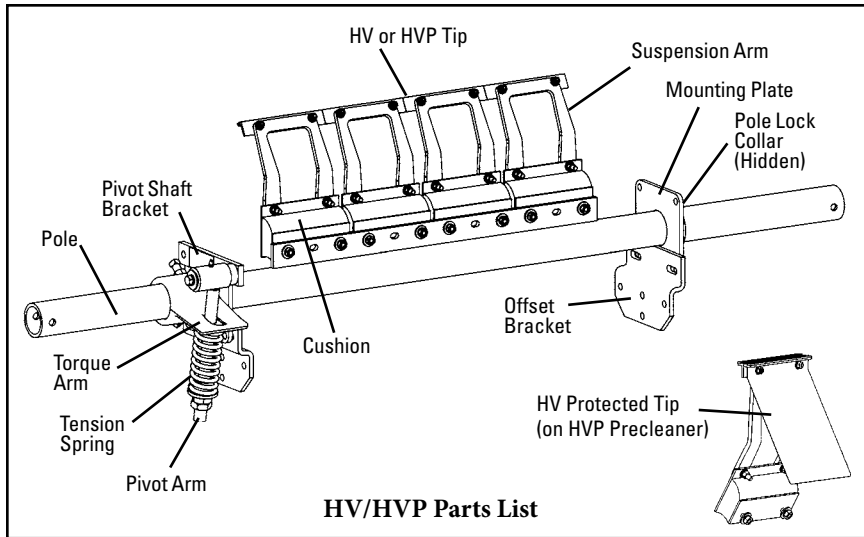

Physically lock out and tag the conveyor at the power source before you begin cleaner installation.

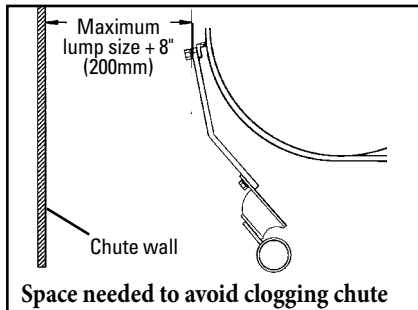

HV/HVP Suspension Arm Size	Pulley Diameter + Belt And Lagging
SS	10" - 19" (250-475mm)
S	20" - 31" (500-775mm)
M	32" - 39" (800-975mm)
L	40" - 47" (1000-1175mm)
LL	48" - 67" (1200-1675mm)

Tools Needed:

- Tape Measure
- Level
- Wrenches or Crescent Wrenches:
 - (1) 5/8" (16mm)
 - (2) 3/4" (19mm)
 - (1) 15/16" (24mm)
 - (2) 1 1/2" (38mm)

1. **Find X, Y & C measurements.** Find the X and Y measurement specifications for the pulley diameter. See charts on page 8. The pulley diameter measurement should include lagging and belt.

Pulley Diameter _____"; X= _____"; Y= _____" C= _____"

Using the correct X and Y coordinates will position the cleaner blades at 15° below the horizontal plane on the head pulley.

2. **Measure head pulley shaft.** Determine the diameter of the pulley shaft and divide by 2. _____"

3. **Locate horizontal line from center of pulley shaft.** Put a level on top of the pulley shaft and draw a horizontal line A. Measure down from Line A half the diameter of the pulley shaft and draw Line B parallel from the pulley shaft (Fig. 1).

4. **Mark X dimension.** Subtract the above dimension (Step 2) from the selected X dimension to establish the modified X dimension. With this new X dimension measure horizontally from the front of the pulley shaft forward on Line B and mark on the chute (Fig. 2).

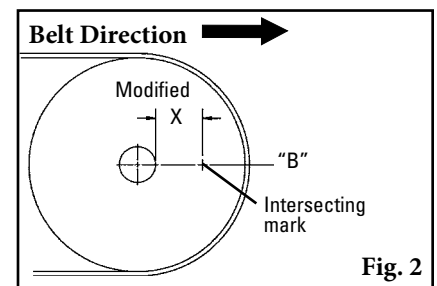
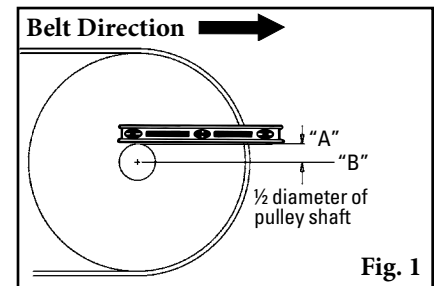

Section 4 – Installation Instructions

4.1 H-Type® Precleaner with V-Tips or Protected V-Tips (cont.)

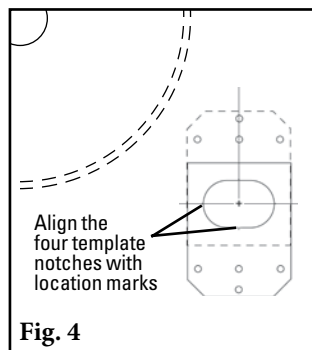
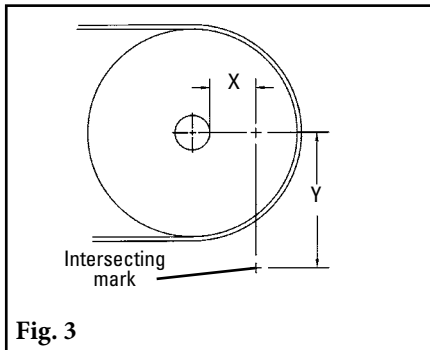

7. **Cut pole opening.** Using template provided, trace and cut the large opening and the mounting holes.
8. **Install offset brackets.** Locate the offset brackets in the correct position on the chute wall and bolt or weld in place (Fig. 5).
9. **Install the pole.** Slide the pole across the pulley and through the chute openings. Allow the tips to hang down.
10. **Install mounting plates.** On one side, slide mounting plate onto pole and with the key slot positioned horizontally and toward the pulley, bolt to the offset bracket, center in slots and tighten (Fig. 6). On opposite side repeat the process, but do not tighten.
11. **Position the pole.** Rotate the pole upward until the tips touch the belt. Center the tips across the belt. While applying light pressure on the center tip, shift the loosened mounting plate until tips are contacting the belt evenly across the full width. Lock cleaner into this position by tightening mounting plate bolts.
12. **Center the cleaner on the belt and lock in place.** Center the tips on the belt and install a pole lock collar on one end of the pole. Slide the collar snugly up to the mounting plate and tighten.
13. **Install the QMT spring tensioner.** Remove the adjusting nuts, bushings and spring from the pivot rod. Insert the pivot arm through the slot in the torque arm. Slide the torque arm onto the pole end (be sure the rotation of the arm is correct to tension the blade) and rotate it until the pivot shaft bracket lines up with the desired bolt holes (Fig. 7). Remove bolts, nuts and washers from mounting plate and reinsert through the pivot shaft bracket and mounting plate.

5. **Determine Y dimension.** From the X mark, draw a line vertically down to the selected Y dimension and make a mark (Fig. 3). This is the correct position for the center of the pole.
6. **Locate offset bracket position.** To locate the position of the offset bracket, position offset bracket template with the large hole notches aligned with the layout lines on the chute wall (Fig. 4). The template can be used with the bracket holes either below or above the Y mark.

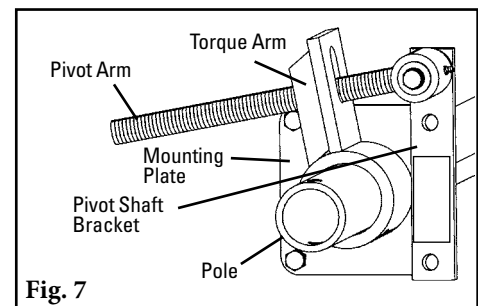
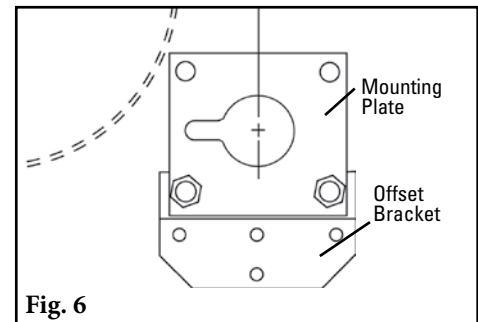
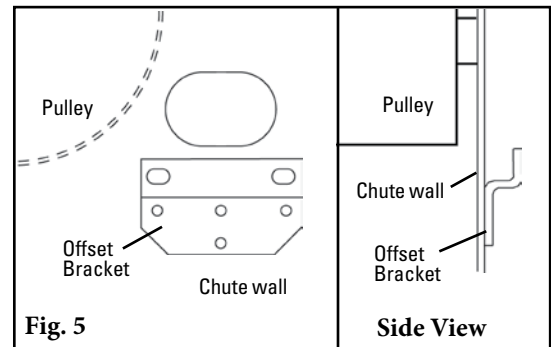

Section 4 – Installation Instructions

4.1 H-Type® Precleaner with V-Tips or Protected V-Tips (cont.)

14. **Reassemble the spring assembly.** Slide the spring, washer and bushings onto the pivot arm and turn the two adjusting nuts so about 1/4" of the pivot arm is exposed above the nuts (Fig. 8).

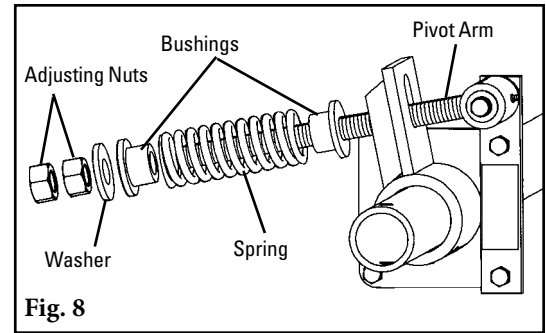

Fig. 8

15. **Tension the blades to the belt.** Rotate the blades until they contact the belt. While holding the spring bushing flat on the torque arm, rotate the torque arm until the pivot arm is against the end of the slot nearest the pole. Tighten the locking bolts and jam nuts on the torque arm (Fig. 9). **NOTE:** The torque arm should be up against the mounting plate.

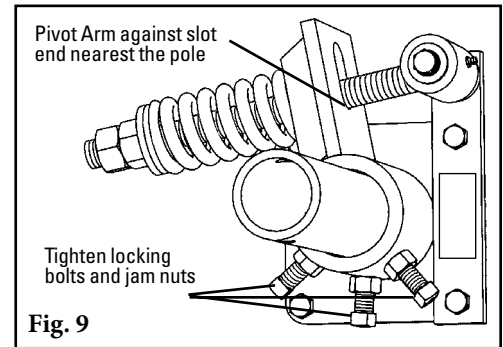

Fig. 9

16. **Set the correct blade tension.** Refer to the chart on the pivot shaft bracket (also shown below) for the spring length required for the belt width. Lightly pull the pivot arm toward the end of the torque arm slot nearest the pole and turn the adjusting nuts until the required spring length is achieved (Fig. 10). Lock the top adjusting nut.

HV/HVP Spring Length Chart (for optimal blade tensioning)						
Belt Width	Tips	Spring Length				
		SS	S	M	L	LL
18"	2	5 1/4"	4 7/8"	4 3/4"	4 1/2"	N/A
24"	3	4 1/2"	4 1/8"	5 3/4"	5 3/4"	N/A
30"	3	4 1/2"	4 1/8"	5 3/4"	5 3/4"	N/A
36"	4	5 3/4"	5 5/8"	5 1/2"	5 3/8"	N/A
42"	5	5 5/8"	5 3/8"	5 1/4"	5 1/8"	4 3/4"
48"	5	5 5/8"	5 3/8"	5 1/4"	5 1/8"	4 3/4"
54"	6	N/A	5 1/8"	5	4 7/8"	6"
60"	7	N/A	4 7/8"	6 1/8"	6"	5 7/8"
72"	8	N/A	6"	6"	5 7/8"	5 3/4"

Purple Spring
 Silver Spring
 White Spring

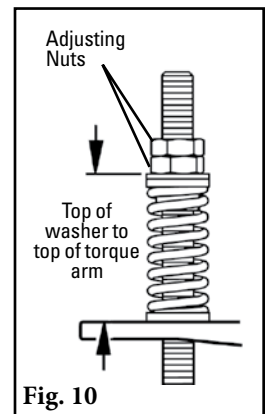

Fig. 10

17. **Verify your "C" dimension** to insure the pole is in the correct position.

Test run the cleaner. Run the conveyor for at least 15 minutes and inspect the cleaning performance. Check the spring length for proper tensioning. Make adjustments as necessary.

Section 4 – Installation Instructions

4.2 Pole Location Charts

Extra Small (SS) V-Tips for Head Pulley Diameters 10" to 19"				
Diameter (Over Belt)	X	Y	C	Gap
10"	1 1/8"	11 1/2"	11 5/8"	2 1/8"
11"	1 5/8"	11 5/8"	11 3/4"	2"
12"	2 1/8"	11 3/4"	12"	1 3/4"
13"	2 5/8"	11 7/8"	12 1/4"	1 5/8"
14"	3 1/8"	12"	12 1/2"	1 1/2"
15"	3 5/8"	12 1/8"	12 3/4"	1 3/8"
16"	4 1/8"	12 1/4"	13"	1 1/4"
17"	4 1/2"	12 3/8"	13 1/4"	1 1/8"
18"	5"	12 1/2"	13 1/2"	1 1/8"
19"	5 1/2"	12 3/4"	13 7/8"	1"
20"	6"	12 7/8"	14 1/8"	7/8"
21"	6 1/2"	13"	14 1/2"	7/8"
22"	7"	13 1/8"	14 7/8"	3/4"
23"	7 1/2"	13 1/4"	15 1/8"	3/4"

Recommended range for tip size
 Optional extended range

Small (S) V-Tips for Head Pulley Diameters 20" to 31"				
Diameter (Over Belt)	X	Y	C	Gap
14"	2 1/8"	14 1/4"	14 3/8"	3"
15"	2 1/2"	14 3/8"	14 5/8"	2 7/8"
16"	3"	14 1/2"	14 7/8"	2 5/8"
17"	3 1/2"	14 5/8"	15"	2 1/2"
18"	4"	14 3/4"	15 1/4"	2 1/4"
19"	4 1/2"	14 7/8"	15 1/2"	2 1/8"
20"	5"	15"	15 7/8"	2"
21"	5 1/2"	15 1/8"	16 1/8"	1 7/8"
22"	5 7/8"	15 1/4"	16 3/8"	1 3/4"
23"	6 3/8"	15 3/8"	16 3/4"	1 5/8"
24"	6 7/8"	15 1/2"	17"	1 1/2"
25"	7 3/8"	15 5/8"	17 3/8"	1 1/2"
26"	7 7/8"	15 3/4"	17 5/8"	1 3/8"
27"	8 3/8"	15 7/8"	18"	1 1/4"
28"	8 7/8"	16 1/8"	18 3/8"	1 1/4"
29"	9 3/8"	16 1/4"	18 5/8"	1 1/8"
30"	9 3/4"	16 3/8"	19"	1"
31"	10 1/4"	16 1/2"	19 3/8"	1"
32"	10 3/4"	16 5/8"	19 3/4"	7/8"
33"	11 1/4"	16 3/4"	20 1/8"	7/8"
34"	11 3/4"	16 7/8"	20 1/2"	3/4"
35"	12 1/4"	17"	20 7/8"	3/4"
36"	12 3/4"	17 1/8"	21 1/4"	3/4"

Medium (M) V-Tips for Head Pulley Diameters 32" to 39"				
Diameter (Over Belt)	X	Y	C	Gap
26"	7 1/4"	17 5/8"	19"	2 3/8"
27"	7 3/4"	17 3/4"	19 3/8"	2 3/8"
28"	8 1/4"	17 7/8"	19 5/8"	2 1/4"
29"	8 3/4"	18"	20"	2 1/8"
30"	9 1/4"	18 1/8"	20 3/8"	2"
31"	9 3/4"	18 1/4"	20 5/8"	1 7/8"
32"	10 1/8"	18 3/8"	21"	1 7/8"
33"	10 5/8"	18 1/2"	21 3/8"	1 3/4"
34"	11 1/8"	18 5/8"	21 3/4"	1 5/8"
35"	11 5/8"	18 3/4"	22 1/8"	1 5/8"
36"	12 1/8"	18 7/8"	22 3/8"	1 1/2"
37"	12 5/8"	19"	22 3/4"	1 3/8"
38"	13 1/8"	19 1/8"	23 1/8"	1 3/8"
39"	13 1/2"	19 1/4"	23 5/8"	1 1/4"
40"	14"	19 3/8"	24"	1 1/4"
41"	14 1/2"	19 1/2"	24 3/8"	1 1/8"
42"	15"	19 5/8"	24 3/4"	1 1/8"
43"	15 1/2"	19 3/4"	25 1/8"	1 1/8"
44"	16"	19 7/8"	25 1/2"	1"
45"	16 1/2"	20"	26"	1"

Large (L) V-Tips for Head Pulley Diameters 40" to 47"				
Diameter (Over Belt)	X	Y	C	Gap
34"	10 1/4"	19 1/2"	22"	1 3/4"
35"	10 3/4"	19 5/8"	22 3/8"	1 5/8"
36"	11 1/4"	19 3/4"	22 3/4"	1 5/8"
37"	11 5/8"	19 7/8"	23 1/8"	1 1/2"
38"	12 1/8"	20"	23 1/2"	1 3/8"
39"	12 5/8"	20 1/8"	23 7/8"	1 3/8"
40"	13 1/8"	20 3/8"	24 1/4"	1 1/4"
41"	13 5/8"	20 1/2"	24 1/2"	1 1/8"
42"	14 1/8"	20 5/8"	25"	1 1/8"
43"	14 5/8"	20 3/4"	25 3/8"	1"
44"	15 1/8"	20 7/8"	25 3/4"	1"
45"	15 1/2"	21"	26 1/8"	7/8"
46"	16"	21 1/8"	26 1/2"	7/8"
47"	16 1/2"	21 1/4"	26 7/8"	3/4"
48"	17"	21 3/8"	27 1/4"	3/4"

Extra Large (LL) V-Tips for Head Pulley Diameters 48" to 67"				
Diameter (Over Belt)	X	Y	Z	Gap
48"	16 5/8"	25 3/4"	30 5/8"	3"
49"	17 1/8"	25 7/8"	31"	2 7/8"
50"	17 5/8"	26"	31 3/8"	2 7/8"
51"	18 1/8"	26 1/8"	31 3/4"	2 3/4"
52"	18 5/8"	26 1/4"	32 1/8"	2 5/8"
53"	19"	26 3/8"	32 1/2"	2 5/8"
54"	19 1/2"	26 1/2"	32 7/8"	2 1/2"
55"	20"	26 5/8"	33 1/4"	2 1/2"
56"	20 1/2"	26 3/4"	33 3/4"	2 3/8"
57"	21"	26 7/8"	34 1/8"	2 3/8"
58"	21 1/2"	27"	34 1/2"	2 1/4"
59"	22"	27 1/8"	34 7/8"	2 1/4"
60"	22 1/2"	27 1/4"	35 1/4"	2 1/8"
61"	22 7/8"	27 3/8"	35 3/4"	2 1/8"
62"	23 3/8"	27 1/2"	36 1/8"	2"
63"	23 7/8"	27 5/8"	36 1/2"	2"
64"	24 3/8"	27 3/4"	37"	1 7/8"
65"	24 7/8"	27 7/8"	37 3/8"	1 7/8"
66"	25 3/8"	28"	37 3/4"	1 3/4"
67"	25 7/8"	28 1/8"	38 1/4"	1 3/4"

Section 4 – Installation Instructions

4.3 Shimming Instructions

Tools Needed:

- (1) 11/16" (38mm) wrench or crescent wrenches
- (1) 1½" (38mm) wrenches or crescent wrenches
- Shim Kit (provided)

NOTE: If all cleaner tips do not make even contact across the width of the belt, the tips will require shimming (Fig. A and Fig. B).

All shimming is done between the cushion and the pole plate (Fig. 2).

1. **Remove tension.** Turn adjusting bolt down until a 1/8" (3mm) gap is gained at the tightest point between the tip and the belt (Fig. 1).

2. **Loosen both cushion nuts on tip to be shimmed.** Push the tip against the head pulley to move the cushion away from the pole plate (Fig. 2).

3. **Determine where to place the shim** (use plastic shims provided).
- To move tip in equally at both ends, place long shim above the cushion studs, centered on the cushion (Fig. 3a).
 - To move tip in at one end only, place a short shim above the cushion stud on the side that must be pulled in (Fig. 3b).
 - Shim tips until 1/8" (3mm) gap is obtained across the entire cleaner width (Fig. 3c).

4. **Reset tip tension.**

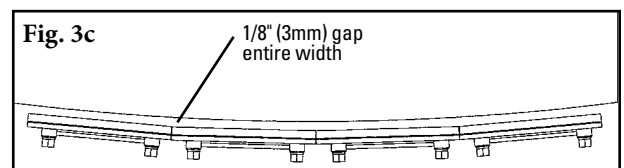
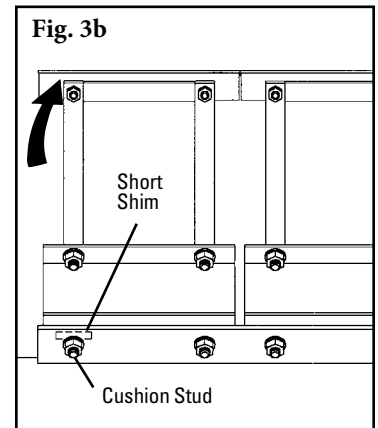
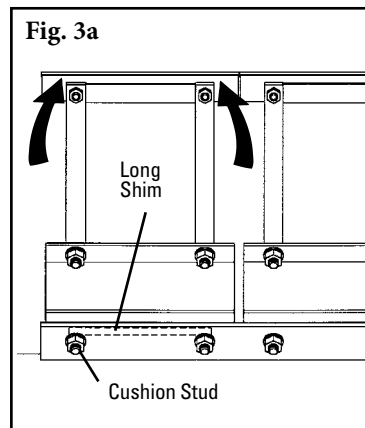
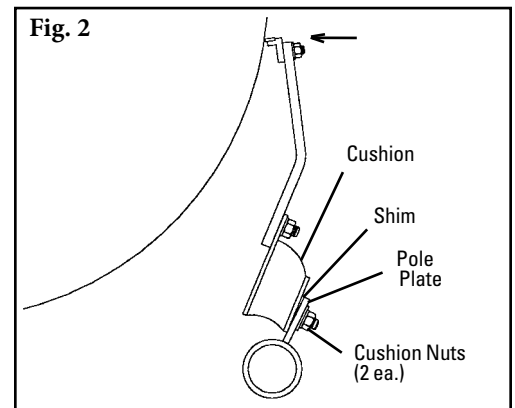
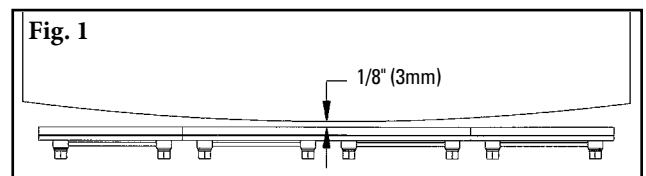
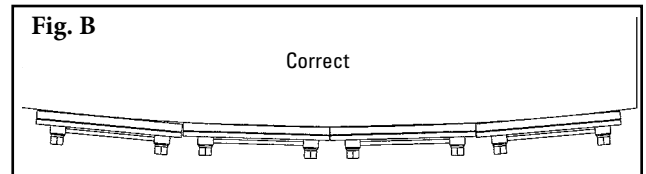
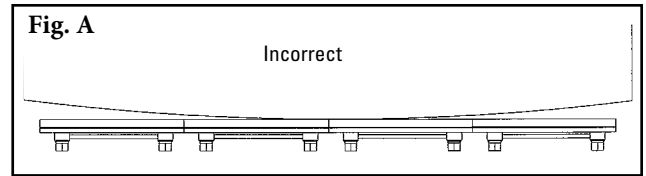

Section 5 – Pre-Operation Checklist and Testing

5.1 Pre-Op Checklist

- Recheck that all fasteners are tightened properly
- Add pole caps
- Apply all supplied labels to the cleaner
- Check the blade location on the belt
- Be sure that all installation materials and tools have been removed from the belt and the conveyor area

5.2 Test Run the Conveyor

- Run the conveyor for at least 15 minutes and inspect the cleaning performance
- Check the tensioner spring for recommended length (proper tensioning)
- Make adjustments as necessary

NOTE: Observing the cleaner when it is running and performing properly will help to detect problems or when adjustments are needed later.

Section 6 – Maintenance

Flexco belt cleaners are designed to operate with minimum maintenance. However, to maintain superior performance some service is required. When the cleaner is installed a regular maintenance program should be set up. This program will ensure that the cleaner operates at optimal efficiency and problems can be identified and fixed before the cleaner stops working.

All safety procedures for inspection of equipment (stationary or operating) must be observed. The H-Type Precleaner operates at the discharge end of the conveyor and is in direct contact with the moving belt. Only visual observations can be made while the belt is running. Service tasks can be done only with the conveyor stopped and by observing the correct lockout/tagout procedures.

6.1 New Installation Inspection

After the new cleaner has run for a few days a visual inspection should be made to ensure the cleaner is performing properly. Make adjustments as needed.

6.2 Routine Visual Inspection (every 2-4 weeks)

A visual inspection of the cleaner and belt can determine:

- If the spring length is the correct length for optimal tensioning.
- If the belt looks clean or if there are areas that are dirty.
- If the blade is worn out and needs to be replaced.
- If there is damage to the blade or other cleaner components.
- If fugitive material is built up on the cleaner or in the transfer area.
- If there is cover damage to the belt.
- If there is vibration or bouncing of the cleaner on the belt.
- If a snub pulley is used, a check should be made for material buildup on the pulley.

If any of the above conditions exist, a determination should be made on when the conveyor can be stopped for cleaner maintenance.

6.3 Routine Physical Inspection (every 6-8 weeks)

When the conveyor is not in operation and properly locked and tagged out a physical inspection of the cleaner to perform the following tasks:

- Clean material buildup off of the cleaner blade and pole.
- Closely inspect the blade for wear and any damage. Replace if needed.
- Check both blade pins for proper installation and condition. Replace if needed.
- Ensure full blade to belt contact.
- Inspect the cleaner pole for damage.
- Inspect all fasteners for tightness and wear. Tighten or replace as needed.
- Replace any worn or damaged components.
- Check the tension of the cleaner blade to the belt. Adjust the tension if necessary using the chart on the cleaner or the one on Page 7.
- When maintenance tasks are completed, test run the conveyor to ensure the cleaner is performing properly.

Section 6 – Maintenance

6.4 Blade Replacement Instructions

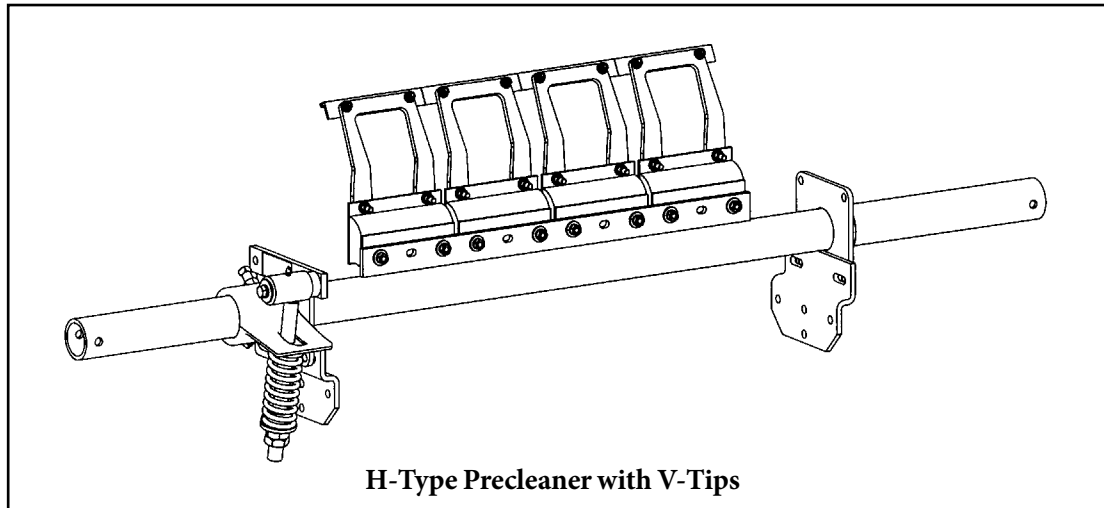

Physically lock out and tag the conveyor at the power source before you begin cleaner installation.

Tools Needed:

- Tape measure
- (2) 1½" (38mm) wrenches or crescent wrenches
- (1) 11/16" (17mm) wrench or crescent wrench
- Wire brush (for cleaning pole)
- Small putty knife (for cleaning pole)

1. **Remove the tension.** Loosen the adjusting nuts on both sides and then turn them out until they are flush with the ends of the pivot arms (Fig. 1). This releases the tension of the blade on the belt.

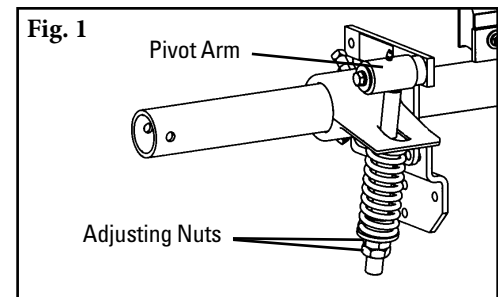

2. **Remove the worn tips.** Remove the nuts on each tip and remove the tips from the suspension arm (Fig. 2). Clean all fugitive material from the pole.

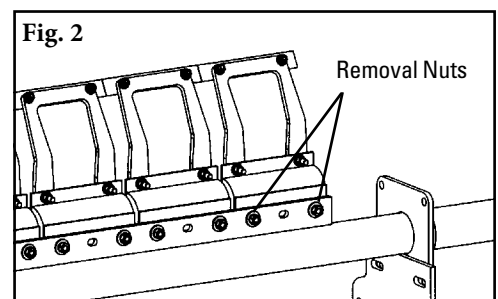

NOTE: If tips are hard to remove use a screwdriver or hammer to loosen it and then remove.

Section 6 – Maintenance

6.4 Blade Replacement Instructions (cont.)

3. **Install the new tips.** Locate each tip onto each suspension arm, then install the hardware to fasten the tip to the cushion (Fig. 3).

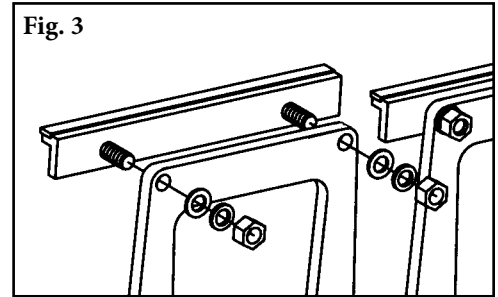

4. **Reset the correct blade tension.** Refer to the chart for the spring length required for the belt width. Lightly pull the pivot arm toward the end of the torque arm slot nearest the pole and turn the adjusting nuts until the required spring length is achieved (Fig. 4). Tighten jam nut.

NOTE: The chart is also on the cleaner's pivot shaft for future reference for retensioning maintenance.

HV/HVP Spring Length Chart (for optimal blade tensioning)						
Belt Width	Tips	Spring Length				
		SS	S	M	L	LL
18"	2	5 1/4"	4 7/8"	4 3/4"	4 1/2"	N/A
24"	3	4 1/2"	4 1/8"	5 3/4"	5 3/4"	N/A
30"	3	4 1/2"	4 1/8"	5 3/4"	5 3/4"	N/A
36"	4	5 3/4"	5 5/8"	5 1/2"	5 3/8"	N/A
42"	5	5 5/8"	5 3/8"	5 1/4"	5 1/8"	4 3/4"
48"	5	5 5/8"	5 3/8"	5 1/4"	5 1/8"	4 3/4"
54"	6	N/A	5 1/8"	5	4 7/8"	6"
60"	7	N/A	4 7/8"	6 1/8"	6"	5 7/8"
72"	8	N/A	6"	6"	5 7/8"	5 3/4"

Purple Spring
 Silver Spring
 White Spring

Test run the cleaner. Run the conveyor for at least 15 minutes and inspect the cleaning performance. Check the spring length for proper tensioning. Make adjustments as necessary.

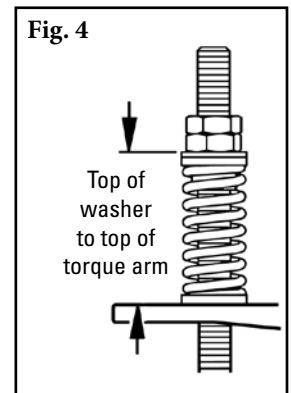

Section 6 – Maintenance

6.5 Maintenance Log

Conveyor Name/No. _____

Date: _____ Work done by: _____ Service Quote # _____

Activity: _____

Date: _____ Work done by: _____ Service Quote # _____

Activity: _____

Date: _____ Work done by: _____ Service Quote # _____

Activity: _____

Date: _____ Work done by: _____ Service Quote # _____

Activity: _____

Date: _____ Work done by: _____ Service Quote # _____

Activity: _____

Date: _____ Work done by: _____ Service Quote # _____

Activity: _____

Date: _____ Work done by: _____ Service Quote # _____

Activity: _____

Section 6 – Maintenance

6.6 Cleaner Maintenance Checklist

Belt Cleaner: _____ Serial Number: _____

Beltline Information:

Beltline Number: _____ Belt Condition: _____

Belt Width: 18" 24" 30" 36" 42" 48" 54" 60" 72"

Head Pulley Diameter (Belt & Lagging): _____ Belt Speed: _____ fpm Belt Thickness: _____

Belt Splice _____ Condition of Splice _____ Number of splices _____ Skived Unskived

Material conveyed _____

Days per week run _____ Hours per day run _____

Blade Life:

Date blade installed: _____ Date blade inspected: _____ Estimated blade life: _____

Is blade making complete contact with belt? Yes No

Blade wear: LEFT _____ MIDDLE _____ RIGHT _____

Blade condition: Good Grooved Smiled Not contacting belt Damaged

Measurement of spring: Required _____ Currently _____

Was Cleaner Adjusted: Yes No

Pole Condition: Good Bent Worn

Lagging: Slide lag Ceramic Rubber Other None

Condition of lagging: Good Bad Other _____

Cleaner's Overall Performance:

(Rate the following 1 - 5, 1 = very poor - 5 = very good)

Appearance: Comments: _____

Location: Comments: _____

Maintenance: Comments: _____

Performance: Comments: _____

Other Comments: _____



Section 7 – Troubleshooting

Problem	Possible Cause	Possible Solutions
Poor cleaning performance	Cleaner under-tensioned	Adjust to correct tension – see spring length chart
	Cleaner over-tensioned	Adjust to correct tension – see spring length chart
	Cleaner installed in wrong location	Verify "C" dimension, relocate to correct dimension
	Cleaner blade worn or damaged	Replace cleaner blade
Rapid Blade Wear	Tension on cleaner too high/low	Adjust to correct tension – see spring length chart
	Cleaner not located correctly	Check cleaner location for correct dimensions
	Blade attack angle incorrect	Check cleaner location for correct dimensions
	Material too abrasive for blade	Option: switch to alternate cleaner with metal blades
	Mechanical splice damaging blade	Repair, skive or replace splice
Center wear on blade (smile effect)	Blade wider than material path	Replace blade with width to match material path
	Tension on cleaner too high/low	Adjust to correct tension – see spring length chart
Unusual wear or damage to blade	Mechanical splice damaging blade	Repair, skive or replace splice
	Belt damaged or ripped	Repair or replace belt
	Cleaner not correctly located	Verify "C" dimension, relocate to correct dimension
	Damage to pulley or pulley lagging	Repair or replace pulley
Vibration or noise	Cleaner not located correctly	Verify "C" dimension, relocate to correct dimension
	Blade attack angle incorrect	Verify "C" dimension, relocate to correct dimension
	Cleaner running on empty belt	Use a spray pole when the belt is empty
	Cleaner tension too high/low	Adjust to correct tension or slight adjust to diminish
	Cleaner locking bolts not secure	Check and tighten all bolts and nuts
	Cleaner not square to head pulley	Verify "C" dimension, relocate to correct dimension
	Material buildup in chute	Clean up build-up on cleaner and in chute
Cleaner being pushed away from pulley	Cleaner tension not set correctly	Ensure correct tension/increase tension slightly
	Sticky material is overburdening cleaner	Increase tension; replace with cleaner with metal tips; replace with larger size cleaner
	Cleaner not set up correctly	Confirm location dimensions are equal on both sides

Section 8 – Specs and CAD Drawings

8.1 Specifications and Guidelines

Pole Length Specifications*					
Cleaner Size		Pole Length		Maximum Conveyor Span	
in.	mm	in.	mm	in.	mm
18	450	66	1650	56	1400
24	600	72	1800	62	1550
30	750	78	1950	68	1700
36	900	84	2100	74	1850
42	1050	90	2250	80	2000
48	1200	96	2400	86	2150
54	1350	102	2550	92	2300
60	1500	108	2700	98	2450
72	1800	120	3000	110	2750

*For special extra long pole length requirements a Pole Extender Kit (#76024) is available that provides 30" (750mm) of extended pole length.
Pole Diameter - 2-7/8" (73mm)

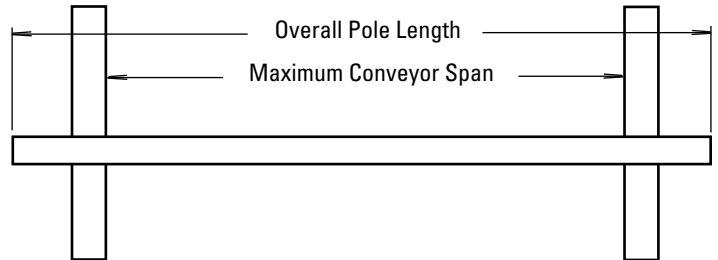

Clearance Guidelines for Installation				
Suspension Arm Size	Horizontal Clearance Required		Vertical Clearance Required	
	in.	mm	in.	mm
SS	7	175	13	325
S	7	175	15	375
M	7	175	16 1/2	413
L	7	175	18 1/2	463
LL	7	175	22	550

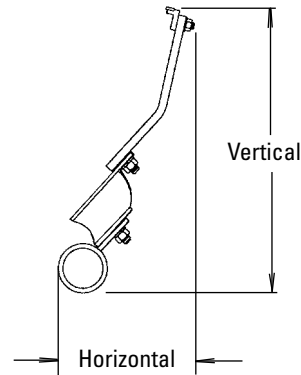

Spring Length Chart with QMT Spring Tensioner						
Belt Width	Tips	Spring Length				
		SS	S	M	L	LL
18"	2	5 1/4"	4 7/8"	4 3/4"	4 1/2"	N/A
24"	3	4 1/2"	4 1/8"	5 3/4"	5 3/4"	N/A
30"	3	4 1/2"	4 1/8"	5 3/4"	5 3/4"	N/A
36"	4	5 3/4"	5 5/8"	5 1/2"	5 3/8"	N/A
42"	5	5 5/8"	5 3/8"	5 1/4"	5 1/8"	4 3/4"
48"	5	5 5/8"	5 3/8"	5 1/4"	5 1/8"	4 3/4"
54"	6	N/A	5 1/8"	5	4 7/8"	6"
60"	7	N/A	4 7/8"	6 1/8"	6"	5 7/8"
72"	8	N/A	6"	6"	5 7/8"	5 3/4"

Purple Spring
 Silver Spring
 White Spring

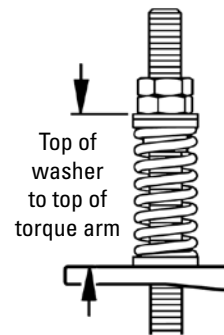

Specifications:

- Maximum Belt Speed.....1000 FPM (5M/sec)
- Temperature Rating.....-30°F to 180°F (-35°C to 82°C)
- Useable Blade Wear Length.....3/8" (9mm)
- Blade Material.....Long Life Tungsten Carbide
(for vulcanized belts only)
- Available for Belt Widths.....18" to 72" (450mm to 1800mm)
Other sizes available upon request.

Section 8 – Specs and CAD Drawings

8.2 CAD Drawings - H-Type Precleaner with V-Tips - SS

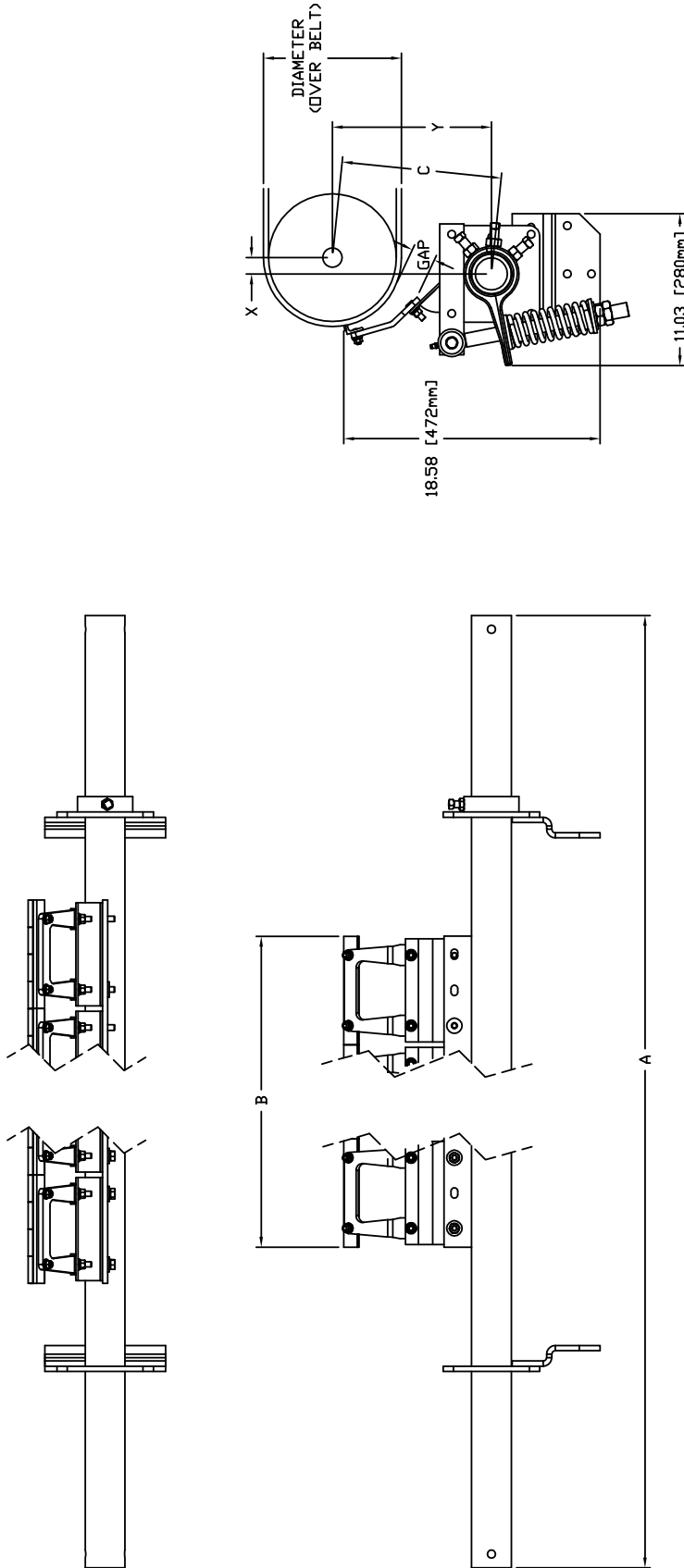

DIAMETER (OVER BELT)	POLE POSITION CHART			
	X	Y	C	GAP
10	1-1/8	11-1/2	11-5/8	2-1/8
11	1-5/8	11-5/8	11-3/4	2
12	2-1/8	11-3/4	12	1-3/4
13	2-5/8	11-7/8	12-1/4	1-5/8
14	3-1/8	12	12-1/2	1-1/2
15	3-5/8	12-1/8	12-3/4	1-3/8
16	4-1/8	12-1/4	13	1-1/4
17	4-1/2	12-3/8	13-1/4	1-1/8
18	5	12-1/2	13-1/2	1-1/8
19	5-1/2	12-3/4	13-7/8	1
*20	6	12-7/8	14-1/8	7/8
*21	6-1/2	13	14-1/2	7/8
*22	7	13-1/8	14-7/8	3/4
*23	7-1/2	13-1/4	15-1/8	3/4

* OPTIONAL EXTENDED RANGE

CLEANER	BELT WIDTH	"A"	"B"	NO. OF BLADES AND CUSHIONS
76101	18"	60"	15.75"	2
76102	24"	66"	23.62"	3
76103	30"	72"	23.62"	3
76104	36"	78"	31.45"	4
76105	42"	84"	39.37"	5
76106	48"	90"	39.37"	5

Section 8 – Specs and CAD Drawings

8.2 CAD Drawings - H-Type Precleaner with V-Tips - S

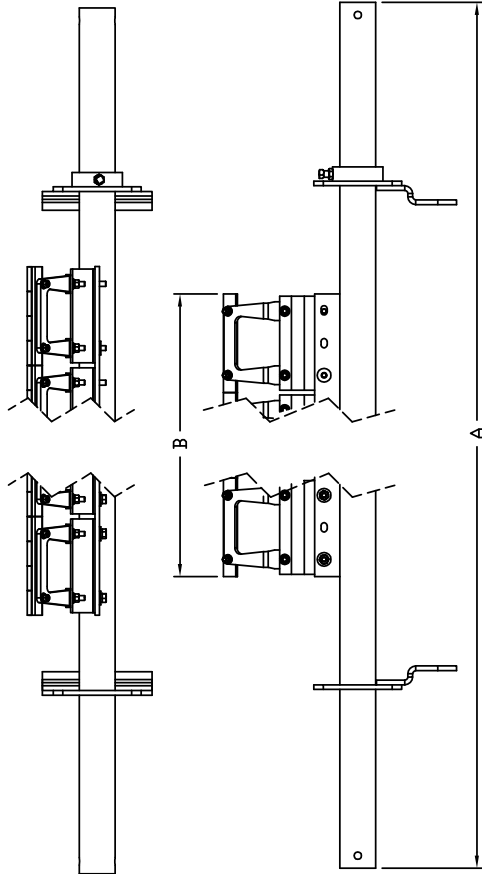
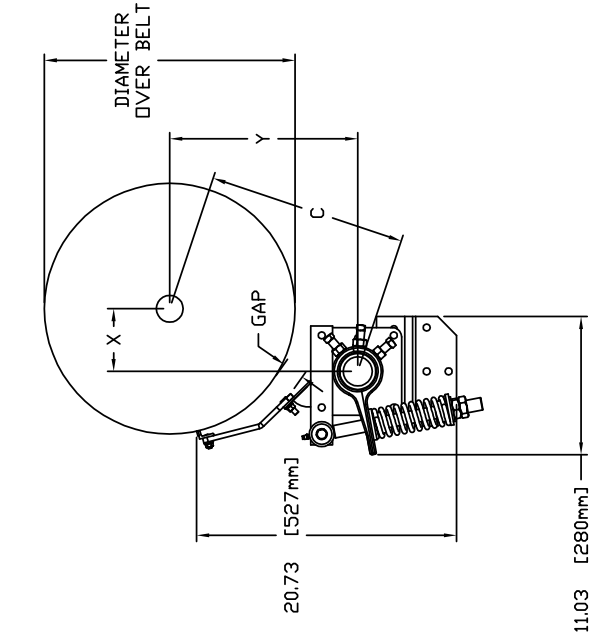

DIAMETER (OVER BELT)	POLE LOCATION CHART			
	X	Y	C	GAP
*14	2-1/8	14-1/4	14-3/8	3
*15	2-1/2	14-3/8	14-5/8	2-7/8
*16	3	14-1/2	14-7/8	2-5/8
*17	3-1/2	14-5/8	15	2-1/2
*18	4	14-3/4	15-1/4	2-1/4
*19	4-1/2	14-7/8	15-1/2	2-1/8
20	5	15	15-7/8	2
21	5-1/2	15-1/8	16-1/8	1-7/8
22	5-7/8	15-1/4	16-3/8	1-3/4
23	6-3/8	15-3/8	16-3/4	1-5/8
24	6-7/8	15-1/2	17	1-1/2
25	7-3/8	15-5/8	17-3/8	1-1/2
26	7-7/8	15-3/4	17-5/8	1-3/8
27	8-3/8	15-7/8	18	1-1/4
28	8-7/8	16-1/8	18-3/8	1-1/4
29	9-3/8	16-1/4	18-5/8	1-1/8
30	9-3/4	16-3/8	19	1
*31	10-1/4	16-1/2	19-3/8	1
*32	10-3/4	16-5/8	19-3/4	7/8
*33	11-1/4	16-3/4	20-1/8	7/8
*34	11-3/4	16-7/8	20-1/2	3/4
*35	12-1/4	17	20-7/8	3/4
*36	12-3/4	17-1/8	21-1/4	13/4

* OPTIONAL EXTENDED RANGE

CLEANER	BELT WIDTH	"A"	"B"	NO. OF BLADES
76190	18"	48"	15.75"	2
76192	24"	54"	23.62"	3
76194	30"	60"	23.62"	3
76196	36"	66"	31.45"	4
76199	42"	72"	39.37"	5
76254	48"	78"	39.37"	5
76107	54"	88"	47.25"	6
76108	60"	108"	55.09"	7
76109	72"	120"	62.96"	8



Section 8 – Specs and CAD Drawings

8.2 CAD Drawings - H-Type Precleaner with V-Tips - M

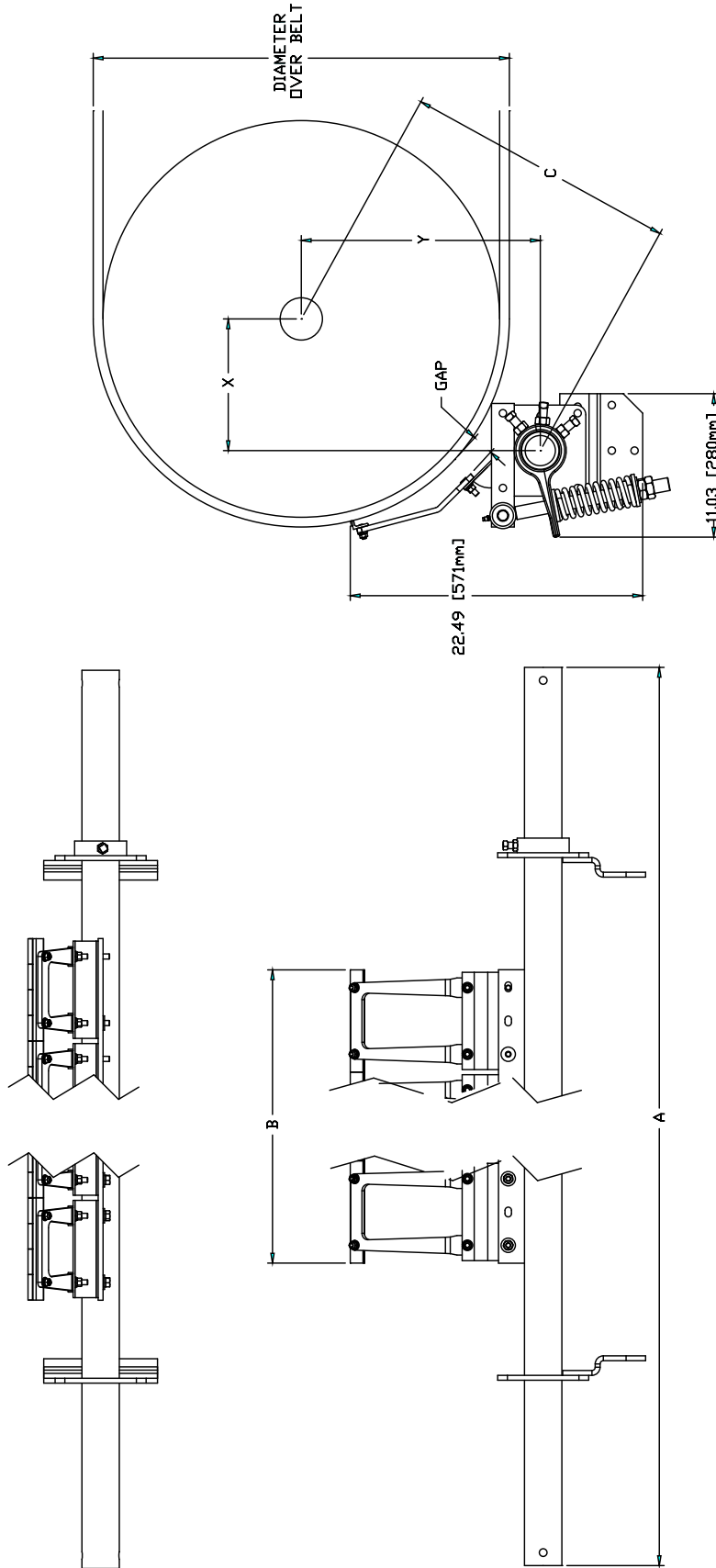

POLE LOCATION CHART					
DIAMETER (INCLUDING BELT)	X	Y	C	GAP	
*26	7-1/4	17-5/8	19	2-3/8	2-3/8
*27	7-3/4	17-3/4	19-3/8	2-3/8	2-3/8
*28	8-1/4	17-7/8	19-5/8	2-1/4	2-1/4
*29	8-3/4	18	20	2-1/8	2-1/8
*30	9-1/4	18-1/8	20-3/8	2	2
31	9-3/4	18-1/4	20-5/8	1-7/8	1-7/8
32	10-1/8	18-3/8	21	1-7/8	1-7/8
33	10-5/8	18-1/2	21-3/8	1-3/4	1-3/4
34	11-1/8	18-5/8	21-3/4	1-5/8	1-5/8
35	11-5/8	18-3/4	22-1/8	1-5/8	1-5/8
36	12-1/8	18-7/8	22-3/8	1-1/2	1-1/2
37	12-5/8	19	22-3/4	1-3/8	1-3/8
38	13-1/8	19-1/8	23-1/8	1-3/8	1-3/8
39	13-1/2	19-1/4	23-5/8	1-1/4	1-1/4
*40	14	19-3/8	24	1-1/4	1-1/4
*41	14-1/2	19-1/2	24-3/8	1-1/8	1-1/8
*42	15	19-5/8	24-3/4	1-1/8	1-1/8
*43	15-1/2	19-3/4	25-1/8	1-1/8	1-1/8
*44	16	19-7/8	25-1/2	1	1
*45	16-1/2	20	26	1	1

* OPTIONAL EXTENDED RANGE

CLEANER	BELT WIDTH	"A"	"B"	NO. OF BLADES
76191	18"	60"	15.75"	2
76193	24"	66"	23.62"	3
76195	30"	72"	23.62"	3
76197	36"	78"	31.50"	4
76251	42"	84"	39.38"	5
76255	48"	90"	39.38"	5
76258	54"	96"	47.25"	6
76261	60"	108"	55.12"	7
76264	72"	120"	63.00"	8

Section 8 – Specs and CAD Drawings

8.2 CAD Drawings - H-Type Precleaner with V-Tips - L

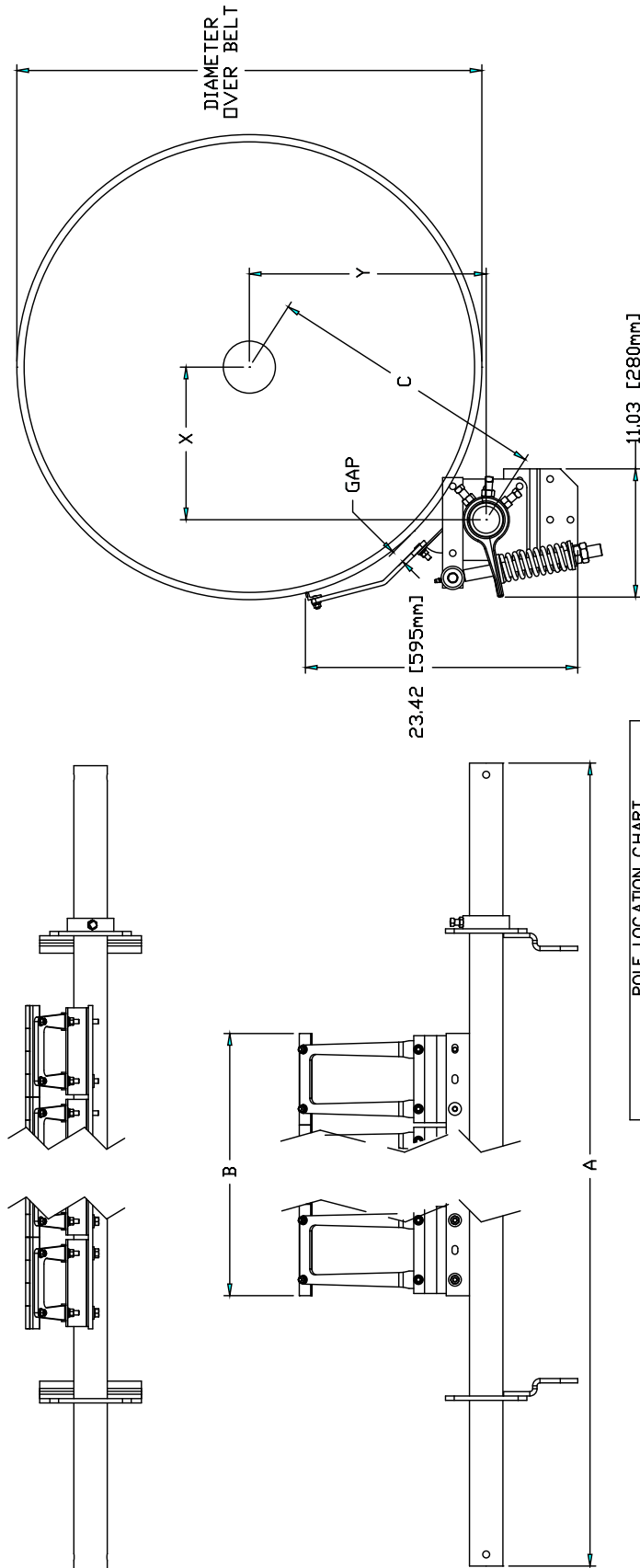

DIAMETER (OVER BELT)	POLE LOCATION CHART			
	X	Y	C	GAP
*34	10-1/4	19-1/2	22	1-3/4
*35	10-3/4	19-5/8	22-3/8	1-5/8
*36	11-1/4	19-3/4	22-3/4	1-5/8
*37	11-5/8	19-7/8	23-1/8	1-1/2
*38	12-1/8	20	23-1/2	1-3/8
*39	12-5/8	20-1/8	23-7/8	1-3/8
40	13-1/8	20-3/8	24-1/4	1-1/4
41	13-5/8	20-1/2	24-1/2	1-1/8
42	14-1/8	20-5/8	25-1/2	1-1/8
43	14-5/8	20-3/4	25-3/8	1
44	15-1/8	20-7/8	25-3/4	1
45	15-1/2	21	26-1/8	7/8
46	16	21-1/8	26-1/2	7/8
47	16-1/2	21-1/4	26-7/8	3/4
*48	17	21-3/8	27-1/4	3/4

* OPTIONAL EXTENDED RANGE

CLEANER	BELT WIDTH	"A"	"B"	NO. OF BLADES
76198	36"	78"	31.50"	4
76252	42"	84"	39.38"	5
76256	48"	90"	39.38"	5
76259	54"	96"	47.25"	6
76262	60"	108"	55.12"	7
76265	72"	120"	63.00"	8



Section 8 – Specs and CAD Drawings

8.2 CAD Drawings - H-Type Precleaner with V-Tips - LL

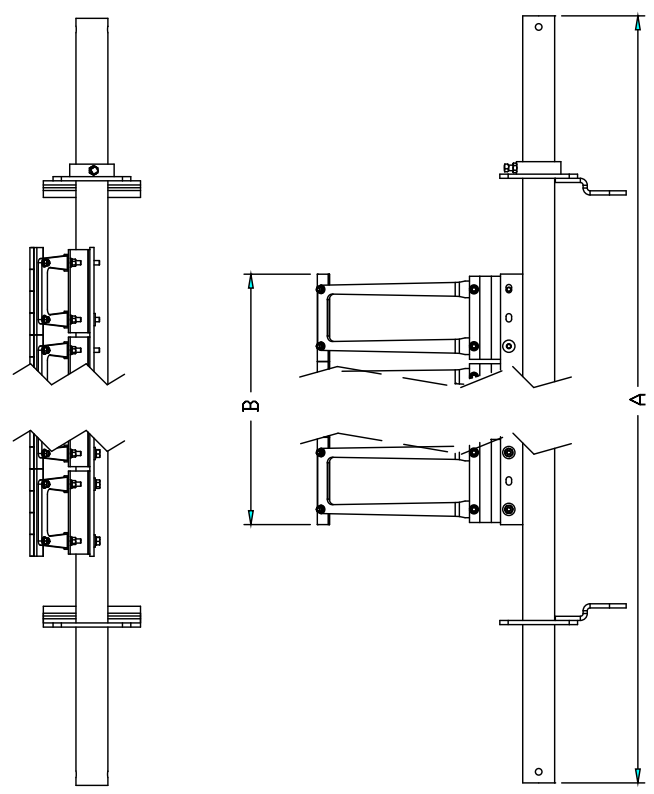
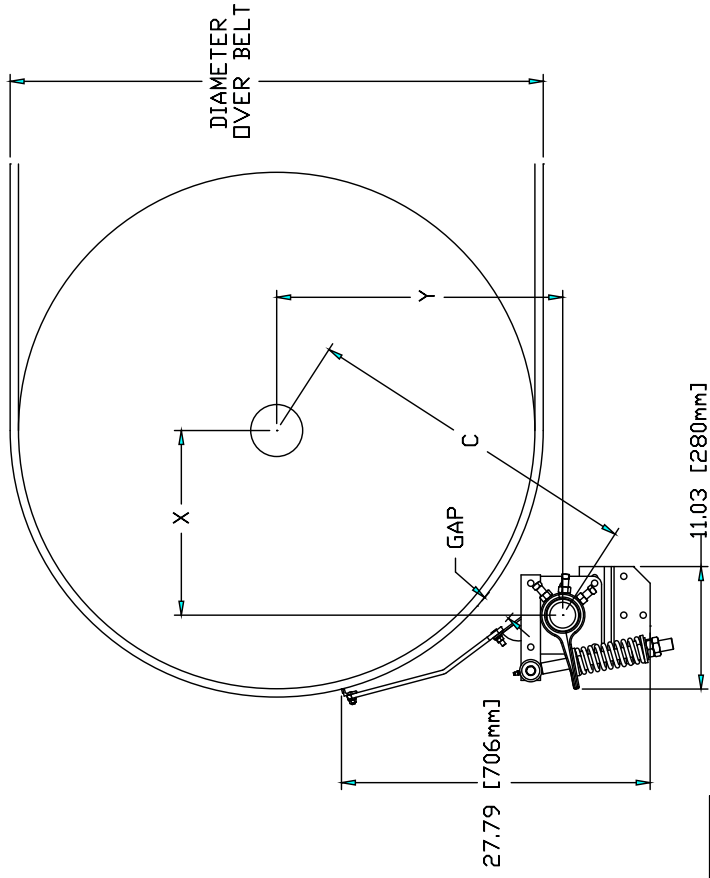

DIAMETER (OVER BELT)	X	Y	C	GAP
48	16-5/8	25-3/4	30-5/8	3
49	17-1/8	25-7/8	31	2-7/8
50	17-5/8	26	31-3/8	2-7/8
51	18-1/8	26-1/8	31-3/4	2-3/4
52	18-5/8	26-1/4	32-1/8	2-5/8
53	19-1/2	26-3/8	32-1/2	2-5/8
54	20	26-1/2	32-7/8	2-1/2
55	20-1/2	26-3/4	33-1/4	2-1/2
56	21	26-7/8	34-1/8	2-3/8
57	21-1/2	27	34-1/2	2-1/4
58	22	27-1/8	34-7/8	2-1/4
59	22-1/2	27-1/4	35-1/4	2-1/8
60	22-7/8	27-3/8	35-3/4	2-1/8
61	23-3/8	27-1/2	36-1/8	2
62	23-7/8	27-5/8	36-1/2	2
63	24-3/8	27-3/4	37	1-7/8
64	24-7/8	27-7/8	37-3/8	1-7/8
65	25-3/8	28	37-3/4	1-7/8
66	25-7/8	28-1/8	38-1/4	1-3/4
67	26-3/8	28-1/2	38-3/4	1-3/4

CLEANER	BELT WIDTH	"A"	"B"	NO. OF BLADES
76253	42"	84"	39.35"	5
76257	48"	90"	39.35"	6
76260	54"	96"	47.22"	6
76263	60"	108"	55.12"	7
76266	72"	120"	63.00"	8

Section 9 – Replacement Parts List

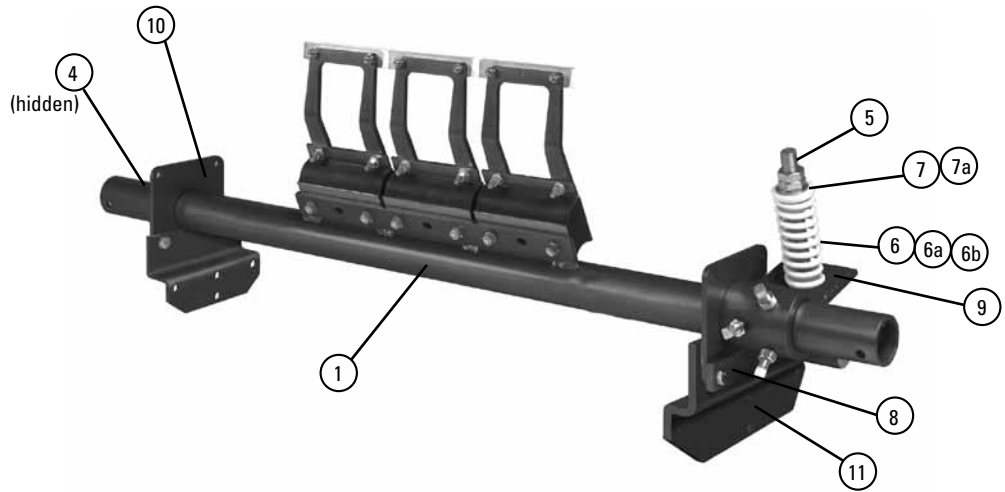

Replacement Parts				
Ref	Description	Ordering Number	Item Code	Wt. Lbs.
1	18" (450mm) Pole	H78P18	76110	41.2
	24" (600mm) Pole	H78P24	76111	46.5
	30" (750mm) Pole	H78P30	76112	50.3
	36" (900mm) Pole	H78P36	76113	55.7
	42" (1050mm) Pole	H78P42	76114	61.1
	48" (1200mm) Pole	H78P48	76115	64.9
	54" (1350mm) Pole	H78P54	76116	70.3
	60" (1500mm) Pole	H78P60	76117	99.8
	72" (1800mm) Pole	H78P72	76118	113.0
2a	H V-Tip* (1 ea.)	HVT8	73042	1.0
2b	H Protected V-Tip* (1 ea.) for vulcanized belts only) (for abusive wear)	HVPT	73631	2.7
3	H SS Suspension Arm*	HSA8SS	73047	0.5
	H S Suspension Arm*	HSA8S	73048	1.0
	H M Suspension Arm*	HSA8M	73049	1.5
	H L Suspension Arm*	HSA8L	73063	2.0
	H LL Suspension Arm*	HSA8LL	73064	2.5
4	Pole Lock Collar* (1 ea.)	MSPPL	75816	1.9
5	Pivot Arm Kit* (1 ea.)	QMTPAK	76096	4.3
6	Tension Spring - Purple (1 ea.)**	QMTS-P	75845	0.6
6a	Tension Spring - White (1 ea.)**	PSTS-W	75898	1.7
6b	Tension Spring - Silver (1 ea.)**	PSTS-S	75899	3.0
7	Bushing Kit - Purple (2 ea.) (for Item 6)	QMTBK-P	76097	0.1
7a	Bushing Kit - White (2 ea.) (for Items 6a & 6b)	QMTBK-W	76098	0.2
8	Pivot Shaft Bracket Kit* (1 ea.)	QMTPSBK	76099	4.3
9	Torque Arm Kit* (1 ea.)	PSTA	75896	11.4
10	Mounting Plate Kit* (2 ea.)	MSPMPK	75811	8.3
11	Offset Bracket Kit* (1 ea.)	HOBK	76399	12.4
12	H SS Tip Shield	HSSTS	74771	0.5
-	H SS Cushion Shield	HSSCS	74772	0.6
-	QMT Spring Tensioner* - Purple (incl. 1 ea. Items 6, 7, 8, 9, & 10)	QMT-P	76074	20.4
-	QMT Spring Tensioner* - White (incl. 1 ea. Items 6, 7a, 8a, 9, & 10)	QMT-W	76075	21.8
-	QMT Spring Tensioner* - Silver (incl. 1 ea. Items 6, 7b, 8a, 9, & 10)	VQMT-S	76402	23.9

*Hardware included
 Note: All poles and tensioners are heavy-duty style.
 Lead time: 1 working day

H-Type Precleaner with V-Tips

- All sizes are now heavy-duty style.
- New, stronger 2 7/8" (72mm) diameter pole.
- New, self-contained spring tensioner.

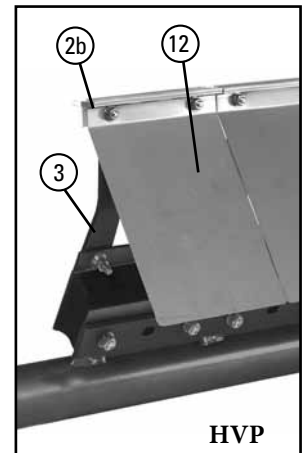
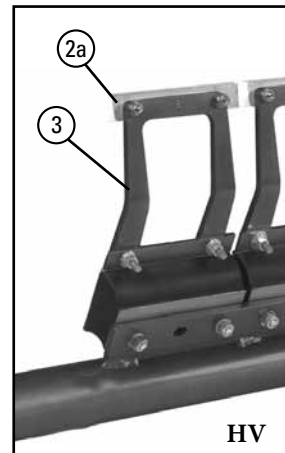

Spring Tensioner Selection Chart			
Cleaner Type And Size	76074 QMT-P	76075 QMT-W	76402 QMT-S
HV			
18" SS, S, M; 24"-30" SS & S	X		
24"-30" M; 36"-48", 54" S, M, L; 60" S		X	
54" LL; 60" M, L, LL; 72"			X
HVP			
18" S, M; 24"-30" S	X		
24"-30" M; 36"-48"; 54" S, M, L; 60" S		X	
54" LL; 60" M, L, LL; 72"			X

Section 10 – Other Flexco Conveyor Products

Flexco provides many conveyor products that help your conveyors to run more efficiently and safely. These components solve typical conveyor problems and improve productivity. Here is a quick overview on just a few of them:

Rockline® EZP1 Precleaner



- Patented ConShear™ blade renews its cleaning edge as it wears
- Visual Tension Check™ for optimal blade tensioning and simple retensioning
- Quick and easy one-pin blade replacement Material Path Option™ for optimal cleaning and reduced maintenance

DRX Impact Beds



- Exclusive Velocity Reduction Technology™ to better protect the belt
- Slide-Out Service™ gives direct access to all impact bars for change-out
- Impact bar supports for longer bar life
- 4 models to custom fit to the application

Rockline® EZS2 Secondary Cleaner



- Long-wearing tungsten carbide blades for superior cleaning efficiency
- Patented FormFlex™ cushions independently tension each blade to the belt for consistent, constant cleaning power
- Easy to install, simple to service
- Works with Flexco mechanical belt splices

PT Max™ Belt Trainer



- Patented “pivot & tilt” design for superior training action
- Dual sensor rollers on each side to minimize belt damage
- Pivot point guaranteed not to freeze or seize up
- Available for topside and return side belts

Flexco Specialty Belt Cleaners



- “Limited space” cleaners for tight conveyor applications
- High Temp cleaners for severe, high heat applications
- A rubber fingered cleaner for chevron and raised rib belts
- Multiple cleaner styles in stainless steel for corrosive applications

Belt Plows



- A belt cleaner for the tail pulley
- Exclusive blade design quickly spirals debris off the belt
- Economical and easy to service
- Available in vee or diagonal models

The Flexco Vision

To become the leader in maximising
belt conveyor productivity for our customers worldwide
through superior service and innovation.



2525 Wisconsin Avenue • Downers Grove, IL 60515-4200 U.S.A.

Telephone: (630)-971-0150 • Fax: (630)-971-1180 • E-mail: info@flexco.com • Web: www.flexco.com

Australia: 61-2-9680-3322 • China: 86-21-33528388 • England: 44-1274-600-942 • Germany: 49-7428-9406-0
India: 91-44-4354-2091 • Mexico: 52-55-5674-5326 • Singapore: 65-6281-7278 • South Africa: 27-11-608-4180

©2011 Flexible Steel Lacing Company. 07/11. For reorder: X2375

