

# 10" BALER BELT LACER™

## Lacing Instructions

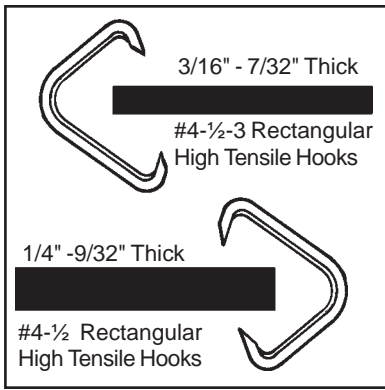

Figure 1

**1. SQUARE BOTH ENDS OF BELT.** If using rough top belt, skive the rough top 1" from belt edge.

**2. GAUGE BELT FOR PROPER SIZE CLIPPER® HOOK** (Fig. 1) or refer to baler manufacturer specs.

**3. ADJUST LACER FOR BELT THICKNESS** by loosening both adjusting knobs. Move both pressure plates to one end of Lacing Tool. Insert belt NEXT TO PRESSURE PLATES. With belt in lacer, tighten both adjusting knobs as tight as possible by hand (Fig. 2).

**4. UNLATCH POWER LEVER, LIFT UP AND REMOVE BELT. TIGHTEN BOTH ADJUSTING KNOBS 1/4 TURN.**

**5. CUT CARD TO 1/2" (4 HOOKS) LESS THAN ACTUAL BELT WIDTH, leaving 1/4" on each side of belt unlaced** (Fig. 3). The trailing edge should have 1 less hook than the leading edge. This helps prevent the splice from catching on the baler structure.

**6. IMPORTANT:** Position Lacing Tool between jaws so one end is aligned with edge of jaws. **DO NOT CENTER LACING TOOL BETWEEN JAWS.**

**7. MOVE EACH PRESSURE PLATE TO END OF JAWS.** Remove lacer pin and place card of hooks into Lacing Tool. Leave the two extra deep slots empty. Reinsert lacer pin (Fig. 4).

**8. LOWER POWER LEVER** until it comes to a natural rest and jaws are snug against hooks. Remove hook carding paper (Fig 5).

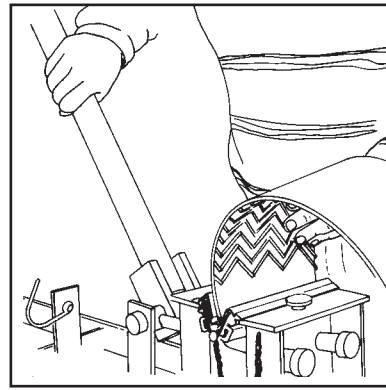

Figure 6

**9. INSERT BELT INTO LACER BETWEEN HOOK POINTS.** Center belt flush onto hook retainer and press Power Lever down. When hook points penetrate belt, press down with both hands until lever comes to a complete stop (Fig. 6).

**10. RAISE POWER LEVER.** Move each pressure plate inward to next section of hooks not yet clinched with pressure plates. Repeat until pressure plates meet in center. Reverse procedure, working outward until all hooks have had contact with the pressure plates twice (Fig. 7).

**11. INSPECT LACE.** If hook clinch is good (Fig. 10), slide Lacing Tool so other end aligns with edge of jaws (Fig. 8). Repeat Step 10.

**12. ONCE SPLICE IS COMPLETE,** remove lacer pin and belt from Lacing Tool. Chamfer corners of belt. Install lacing on other belt end. Insert .109" connecting pin to complete splice (Fig. 9).

**13. IF BELT IS WIDER THAN 10",** repeat Steps 7 and 8. Insert last 2 laced hooks into extra deep slots; hold unlaced section of belt flush on hook retainer and between hook points. Repeat Steps 9 through 11.

**GOOD CLINCH:** Hook legs are parallel, 1/2 of wire diameter is embedded into belt, and hook points have penetrated through belt.

**OVER CLINCH:** Functional, but not optimal splice. To adjust for additional splices slightly turn both adjusting knobs counter-clockwise.

**UNDER CLINCH:** If belt is still in lacer, simply tighten adjusting knobs 1/8 turn tighter and repeat Step 9. Repeat until a good clinch is achieved. If belt is out of lacer, adjust lacer for future splices by turning knob 1/8 turn tighter.

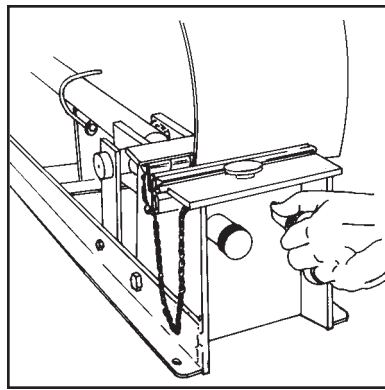

Figure 2

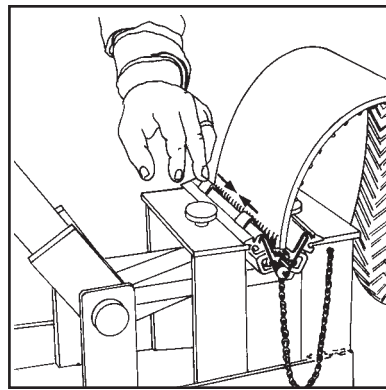

Figure 7

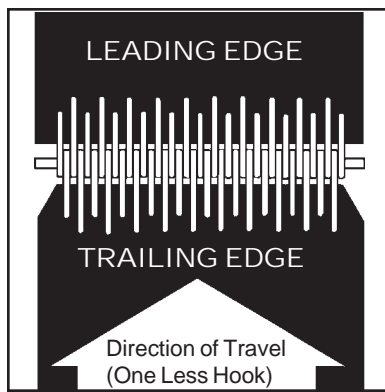

Figure 3

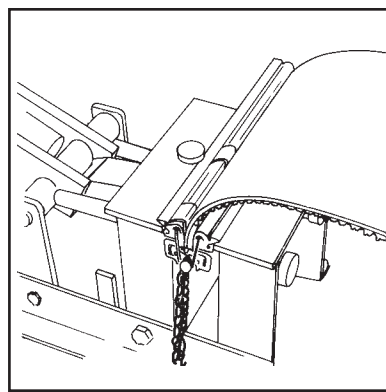

Figure 8

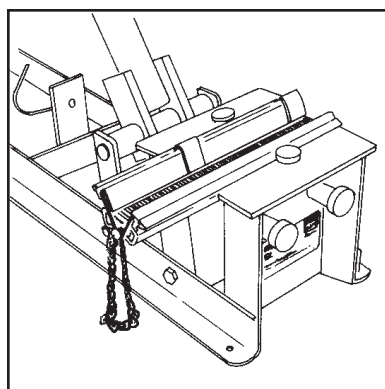

Figure 4

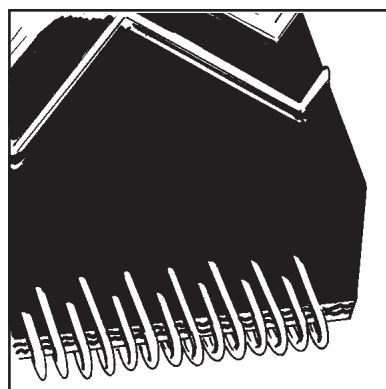

Figure 9

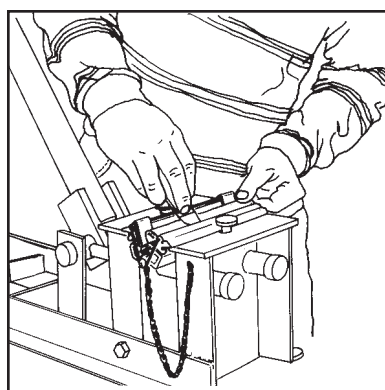

Figure 5

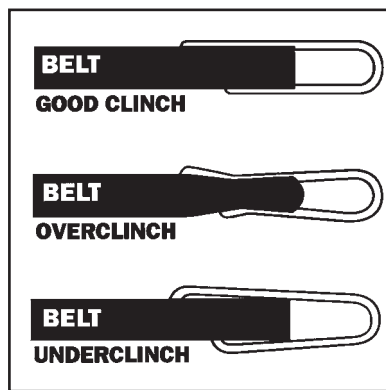
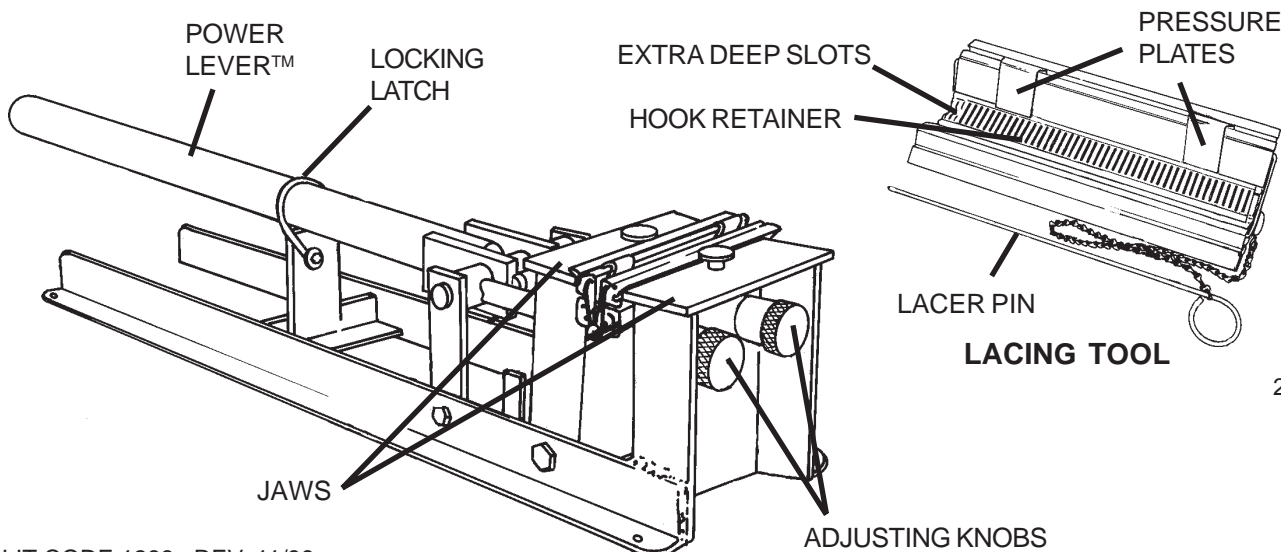

Figure 10



CLIPPER BELT LACER COMPANY  
A wholly owned subsidiary of:  
FLEXIBLE STEEL LACING COMPANY  
2525 Wisconsin Avenue • Downers Grove, IL 60515-4200  
630-971-0150 • Fax: 630-971-1180

