

Installing Flexco® SR™ Fasteners with the Flexco® Electric Powered Rivet Driver and the Standard MSRT Installation Tool

Warning: Follow all maintenance and safety precautions that are noted in the Hitachi H45FRV manual included in this kit.

We recommend a trial drive prior to production installation. Use of this driver will vary with the length of the rivet and the type of belt you are using.

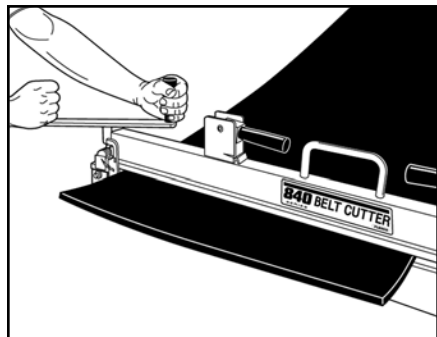

1. Square belt using centerline method. Cut belt 2-3" (50-75 mm) behind old splice using Flexco 840 Series Belt Cutter. Skive belt when top cover permits.

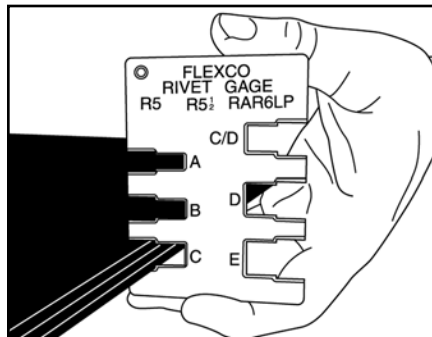

2. Measure belt thickness from cut edge using gauge or tape measure. Select correct size SR rivets for your belt thickness.

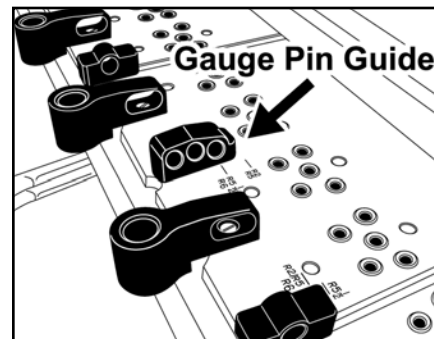

3. Place tool on wooden board, width of the conveyor framework, for support. Lift and turn gauge pin guide to correct fastener size.

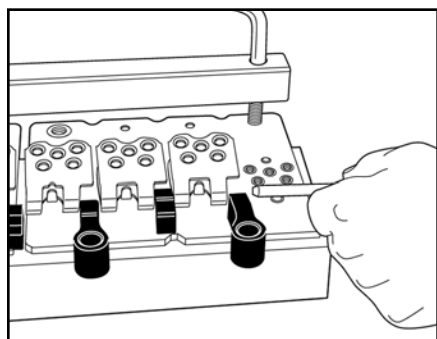

4. Center fastener strip on tool, Flexco stamp facing up. Holes on fasteners and anvil plate must line up. Insert gauge pin through guides and fastener loops.

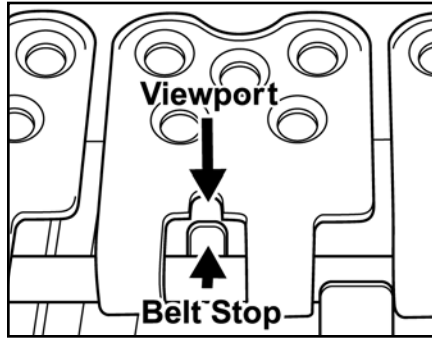

5. Center belt in fastener strip. Look through viewports, belt end should be tight against belt stops. Tighten hold down bar to secure belt.

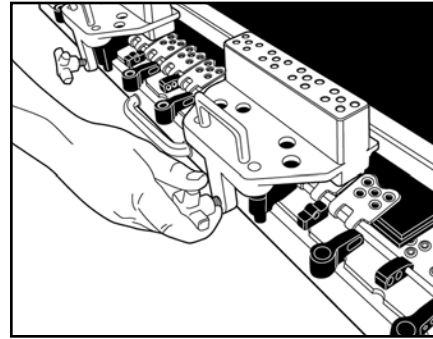

6. Set all fastener top plates with hammer blows. Place SR700 guide blocks at each end of the fastener strip and tighten clamping screws. Spray guide block with SL5 Silicone.

Note: Spray guide blocks with SL5 silicone.

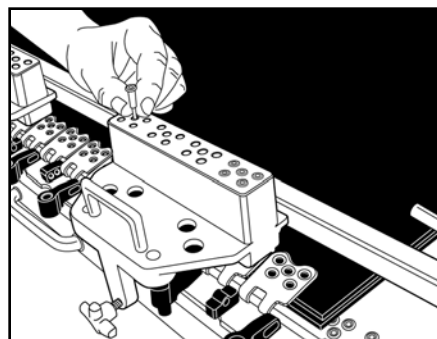

Individual Rivets

7A. Load guide block with individual rivets. Reduce installation time by adding guide blocks across tool.

Rapid Loader™ Collated Rivets

Reduce installation time using Rapid Loader™ Collated Rivet Strips.

7B. If a shorter strip is needed, break off extra plates by bending strip at checkpoints.

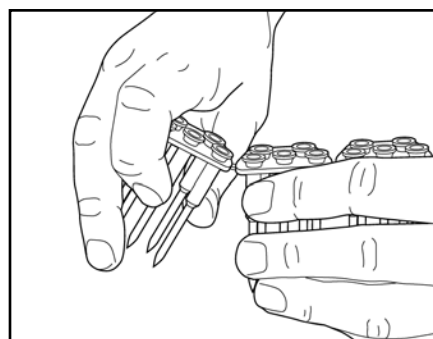

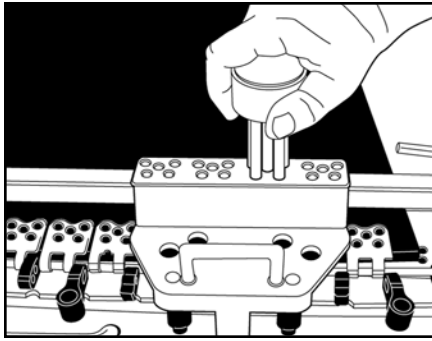

Individual Rivets

8A. Using the SR759 push rivets into guide block.

Rapid Loader™ Collated Rivets

8B. Insert pilot nails into guide block holes. Using a hammer, hit collated rivets to release rivets from plastic. Remove plastic from guide block.

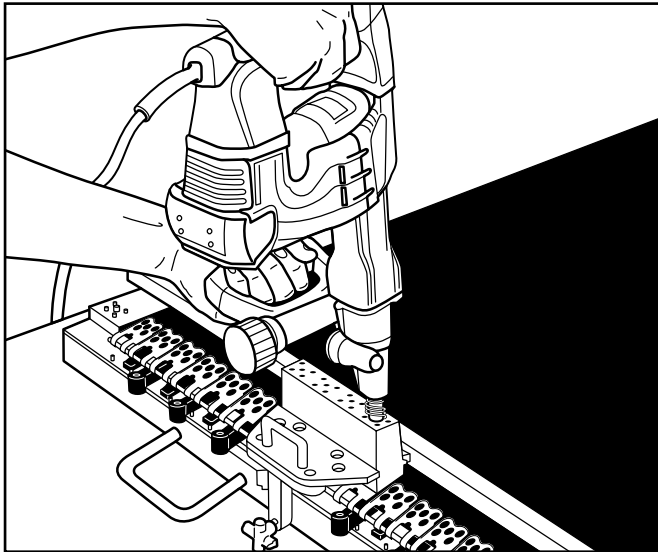
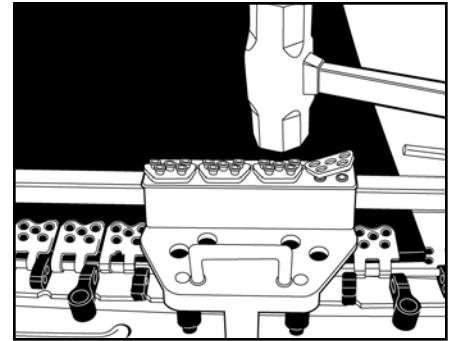

9. Adjust setting dial for rivet size – see chart below. Insert the punch directly into the SR700 Guide Block. Keeping the tool perpendicular to the base, pull the trigger to fire the driver. Push down on the driver slightly and maintain force on the driver until you feel the rivet set. This should take approximately 1 to 2 seconds per rivet depending on the length of the rivet and the type of belt.

Tool Setting Guidelines

Tool Setting	Rivet size range
2	A,B
3	A,B,C
4	C,C/D,D
5	D & up

Note: Tool settings will require adjustment for variations in belt thickness and construction.

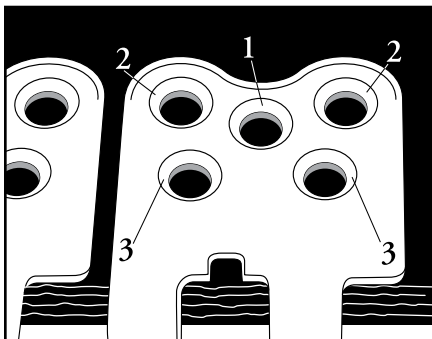

10. Drive rivets into the center hole of both end plates. This will anchor fastener strip in position. Continue to drive all remaining rivets into holes in the sequence shown above.

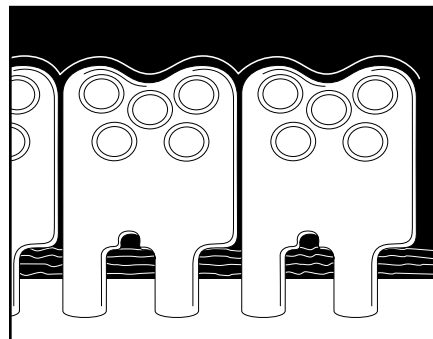

11. Remove guide block(s) and make sure rivets are set completely. Complete belt end by moving the block across the width of the belt and continue driving rivets.

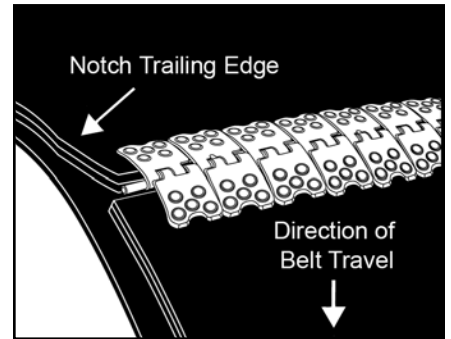

12. Repeat steps 1-11 on other belt end. Bring belt ends together and insert hinge pin. Notch trailing edge of belt only. Splice is complete.



Flexible Steel Lacing Company

2525 Wisconsin Avenue
Downers Grove, IL 60515-4200 U.S.A.
Telephone: (630)-971-0150
Fax: (630)-971-1180
E-mail: info@flexco.com



www.flexco.com

Australia: 61-2-9680-3322 • England: 44-1274-600-942 • Germany: 49-7428-9406-0 • Mexico: 52-55-5674-5326 • Republic of South Africa: 27-11-608-4180

©2006 Flexible Steel Lacing Company. Flexco® is a registered trademark, and SR™ a trademark of Flexible Steel Lacing Company 11/06. Part # X2052