

MHS HD SECONDARY CLEANER

INSTALLATION INSTRUCTIONS

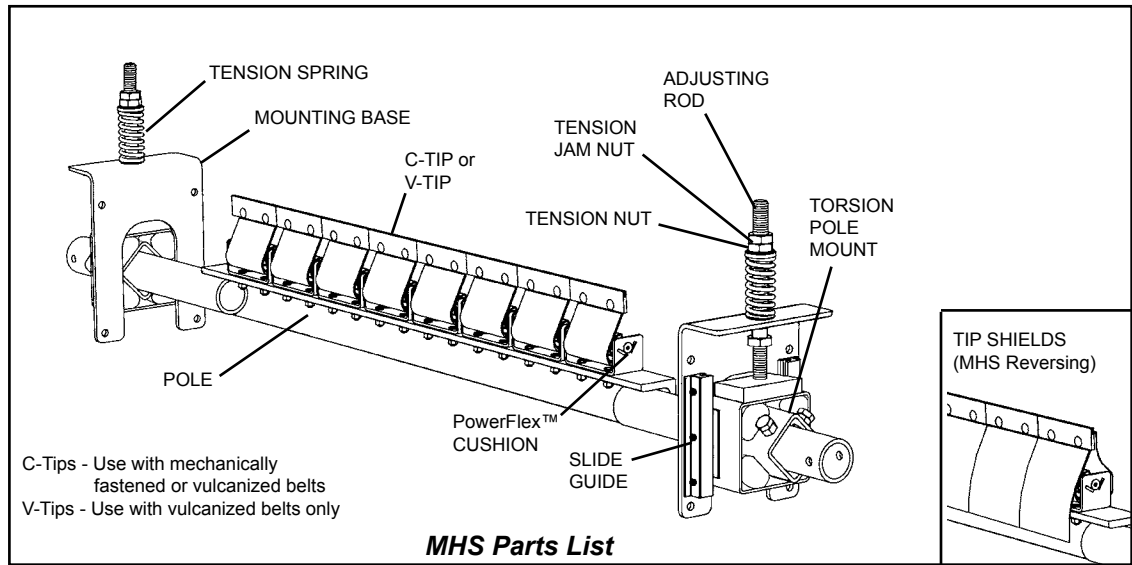

PHYSICALLY LOCK OUT AND TAG THE CONVEYOR AT THE POWER SOURCE BEFORE YOU BEGIN CLEANER INSTALLATION.

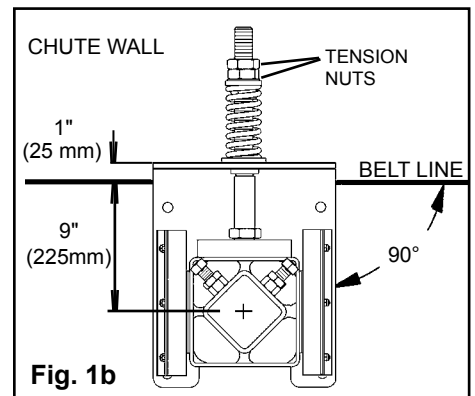
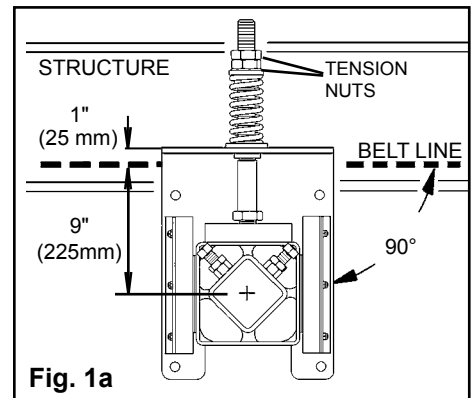
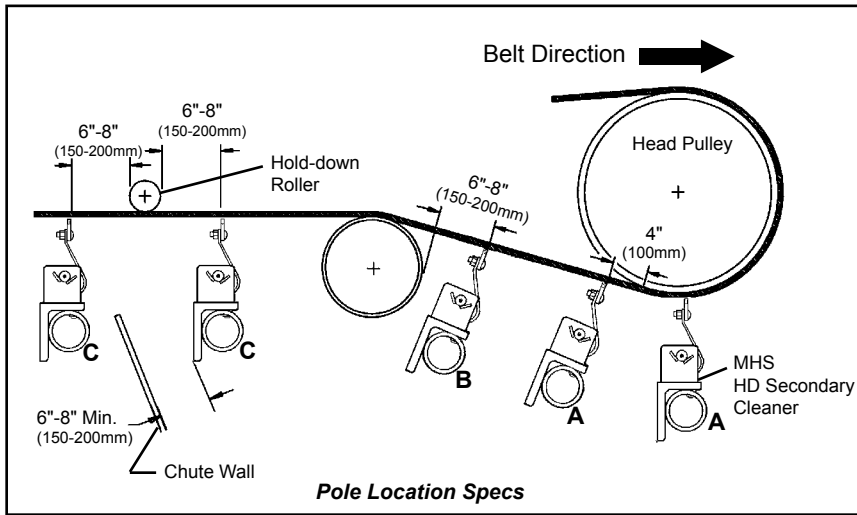

- 1. Install the spring tensioner mounting bases.** (For push-up tensioning refer to additional instruction sheet included in packet.) Clamp the mounting base into position so the top flange of the base is 1" above the belt (Fig. 1a). Bolt or weld the mounting base in place. Locate and install the mounting base on the opposite side. Adjust the tension nuts on each side so the center of the torsion pole mount is 9" (225mm) below the belt line.

NOTE: For chute mounting, a belt location line must be drawn on the chute wall so the mounting base can be aligned with the belt (Fig. 1b). Cut access holes as needed.

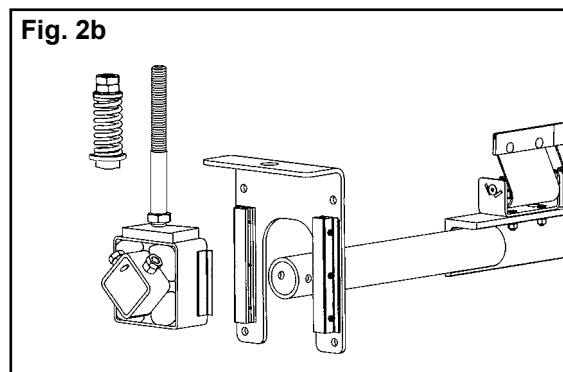
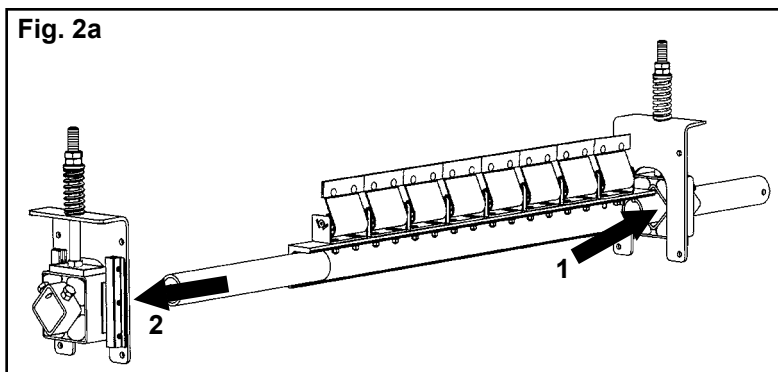

2. Install the pole. Slide the pole into one torsion pole mount as far as needed and locate the other end into the opposite mount (Fig. 2a). If there is not enough space, remove one of the torsion pole mounts from the mounting base, slide the pole through the mounting base and reassemble (Fig. 2b).

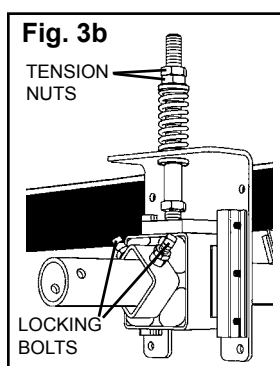
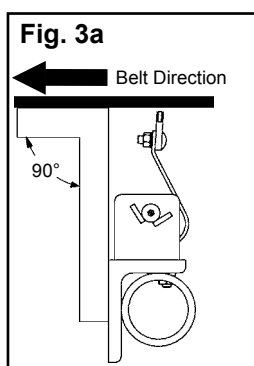

3. Set the blade angle. Center the pole/blades on the belt. Using a standard square, rotate the pole until the center angle of the pole is perpendicular to the belt (Fig. 3a). Tighten the two locking bolts on each torsion pole mount to lock the pole in place (Fig. 3b). There should be no blade-to-belt contact while locking the pole in the correct position. If contact occurs, lower the pole by turning the adjusting rod tension nuts and reset the angle.

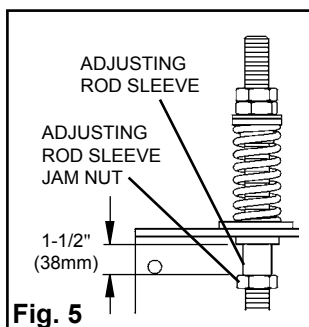
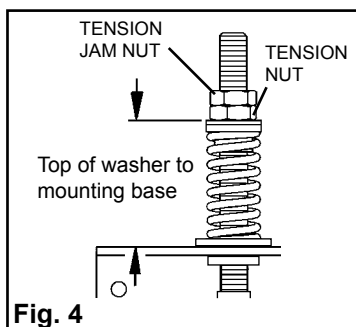

4. Set the blade tension. Loosen the top tension jam nuts on both sides. Turn the tension nuts until the correct spring compression is reached (Fig. 4). Spring compression is determined by spring length. See the chart below for the correct spring length for your belt width.

5. Set adjusting rod sleeve. After setting the blade tension, screw the adjusting rod sleeve into the UHMW bushing until 1-1/2" (38mm) is showing (Fig. 5). Tighten the adjusting rod sleeve jam nut.

6. Test run the cleaner and inspect the cleaning performance. If vibration occurs or more cleaning efficiency is desired, increase the blade tension by making 1/8" compression adjustments on the tension springs.

SPRING LENGTH CHART

BLADE WIDTH	WHITE SPRING	SILVER SPRING	BLACK SPRING
18"	3 3/8"	4"	N/A
24"	3 1/8"	3 7/8"	N/A
30"	2 7/8"	3 3/4"	N/A
36"	N/A	3 3/4"	3 7/8"
42"	N/A	3 5/8"	3 3/4"
48"	N/A	3 1/2"	3 5/8"
54"	N/A	3 3/8"	3 5/8"
60"	N/A	3 1/4"	3 1/2"
72"	N/A	N/A	3 3/8"
84"	N/A	N/A	3 1/8"



1995 Oak Industrial Dr. NE • Grand Rapids, MI 49505 U.S.A.
 Telephone: (616)-459-3196 • Fax: (616)-459-4976 • E-mail: info@flexco.com • Web: www.flexco.com

Australia: 61-2-9680-3322 • China: 86-21-33528388 • England: 44-1274-600-942
 Germany: 49-7428-9406-0 • Mexico: 52-55-5674-5326 • South Africa: 27-11-608-4180

©2008 Flexible Steel Lacing Company. Mineline® is a registered trademark.
 U.S. Patent No. 6,823,983. 05-09. For Reorder: X1271

