

Eliminator[®] Belt Cleaning Systems

U-Type[®] Secondary Cleaner

Instructions for Installation

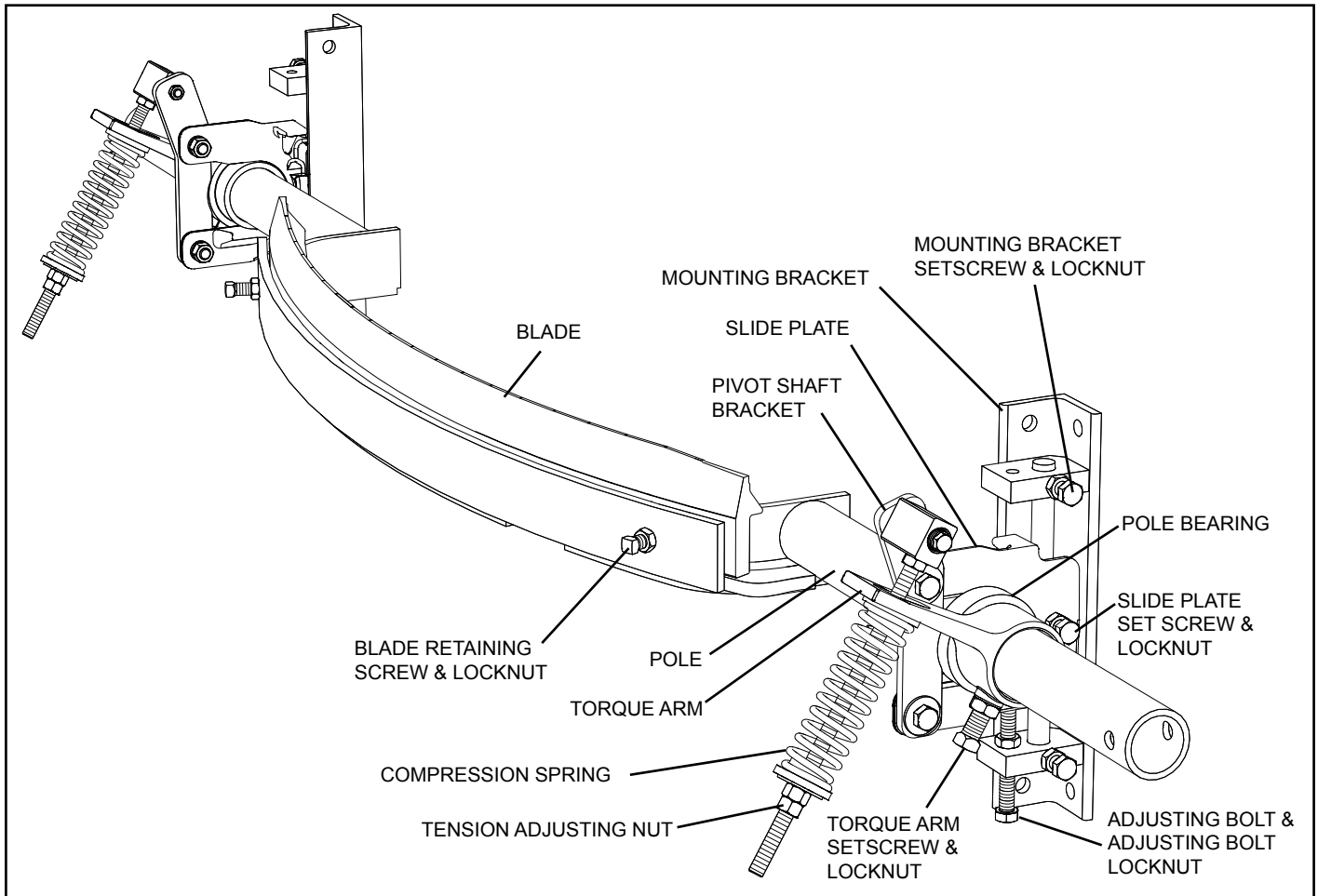

TOOLS NEEDED:

- TAPE MEASURE
- 3/4" (19mm) WRENCH
- RATCHET WITH 3/4" (19mm) SOCKET
- SCREWDRIVER
- (2) 6" C-CLAMPS (Optional for locating mounting brackets)
- 16" x 24" SQUARE (Optional for locating belt height)
- PERMANENT MARKER
- CUTTING TORCH AND/OR WELDER

BEFORE YOU BEGIN:

- **PHYSICALLY LOCK OUT AND TAG THE CONVEYOR AT THE POWER SOURCE.**
- Double-check the blade type needed for your application:
 - F-Blade** - for mechanically spliced belts.
 - C-Blade** - for Flexco[®] Solid Plate mechanically spliced and vulcanized belts.
 - V-Blade** - for vulcanized belts. Can be used with mechanical splices (solid bolt fasteners) that are recessed (skived) into the belt cover (bolts must be ground on plate fasteners).
- For chute mounting it is necessary to cut an access hole to allow for installation and inspections. See dimension requirements on the back page.
- Follow all safety precautions when using a cutting torch.
- If welding, protect all fastener threads from weld spatter.
- For cleaner clearance requirements see chart.

Clearance Requirements for Installation					
U Cleaner Size	Clearance		U Cleaner Size	Clearance	
	in.	mm		in.	mm
18"	5 1/2	140	48"	9 1/2	242
24"	6 1/2	166	54"	9 1/2	242
30"	7 1/2	191	60"	9 1/2	242
36"	7 1/2	171	72"	10 1/4	261
42"	8 1/2	217	84"	10 1/4	261

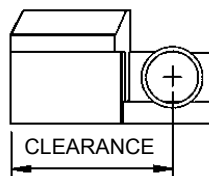

STEP 1. Choose the position on the conveyor where the cleaner will be installed (Fig. 1).

The U-Type® Belt Cleaner may be positioned at any spot from where the belt leaves the head pulley on down the conveyor line (see positions A to B). If a chute area is too small due to a snub pulley, it may be necessary to mount the cleaner behind the chute (see position C). In chute applications a minimum of 6"-8" (150mm-200mm) is required between the cleaner and the chute wall to prevent clogging of material.

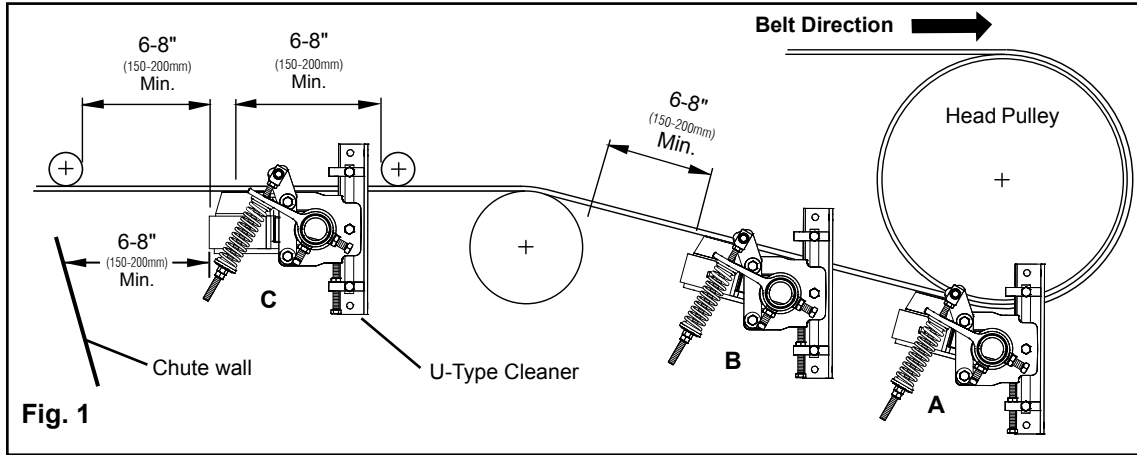

STEP 2. Install the mounting brackets onto the structure.

- Using the 16" x 24" square, lightly raise the return side belt (take out cupping or sagging on edges) to find the belt's true parallel path to the structure; and mark reference point #1 on the structure on both sides of the conveyor. Measure down 3" (75mm) from reference point #1 on both sides and mark reference point #2 (Fig. 2a).
- Position the mounting brackets so the centerline marks on the brackets are in line with reference points #2 on the structure (Fig. 2b).
- Clamp or weld into position.

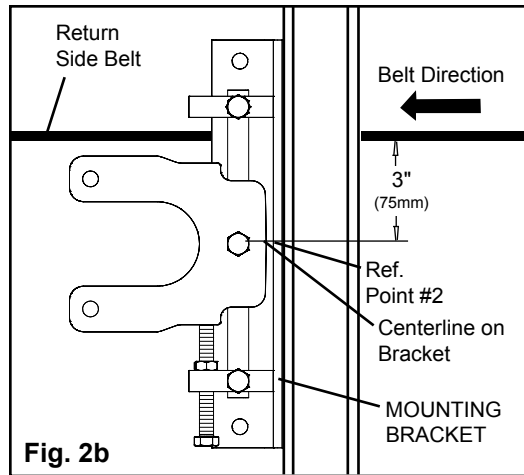
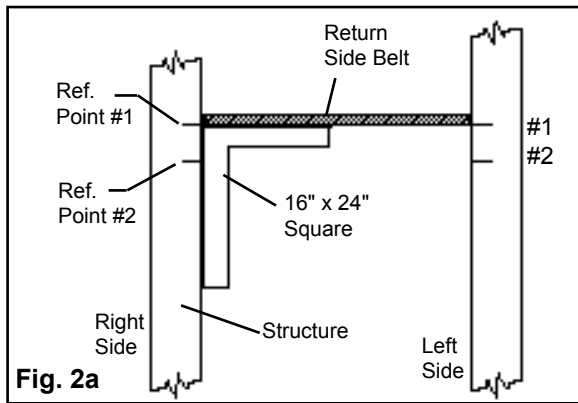

STEP 3. Install the cleaner pole into the slider plates in both mounting brackets.

- Attach the pivot shaft bracket on one slider plate and insert one pole bearing with the flange facing away from the belt (Fig. 3a).
- Slide the pole through the pole bearing and the torque arm, then position it into the other slider plate.
- Slide the second pole bearing and torque arm onto the pole and attach the pivot shaft bracket to the remaining slider plate (Fig. 3b).

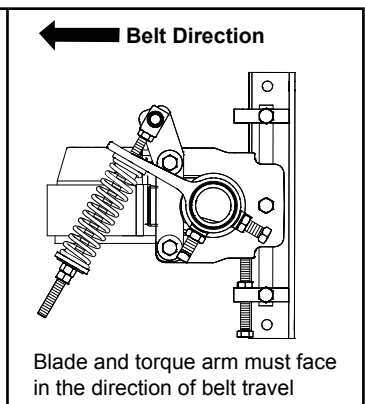
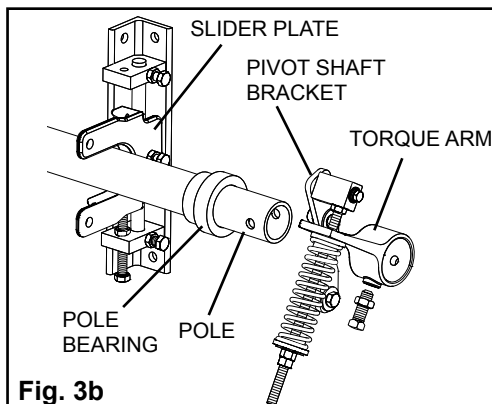
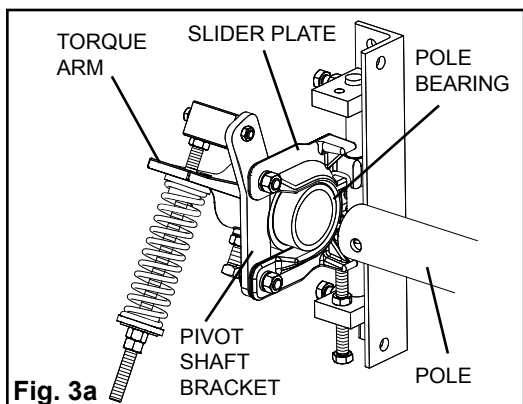

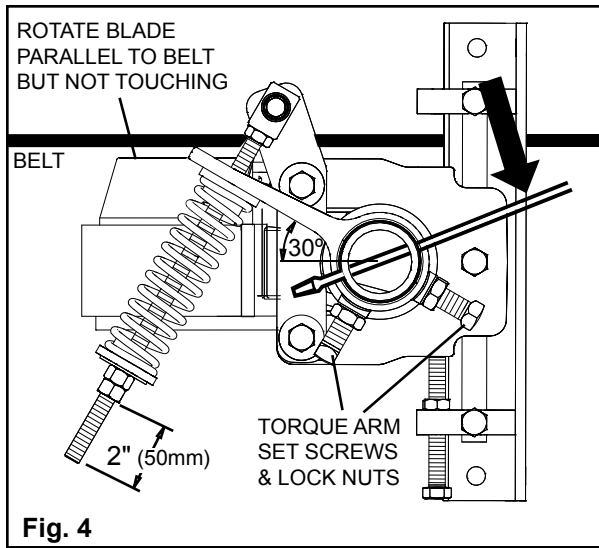

Fig. 4

STEP 4. Tighten adjusting arm set screws.

- Insert a screwdriver or small rod through the holes on the end of the cleaner pole. Rotate the cleaner blade into a position parallel to the belt (Fig. 4). The blade should not be touching the belt at this time.
- Tighten the torque arm set screws and lock nuts on both sides of the cleaner. The angle between the torque arm and the pole should be about 30°, or approx. 2" (50mm) of visible thread showing on bottom end of rod. (Fig. 4).

STEP 5. Make the final adjustment of the blade to the belt.

- Loosen the bearing mount set screws and lock nuts. Adjustments will be made by turning the adjusting bolts either up or down (Fig. 5).
- Adjust the blade either up or down until both blade ends and the center make full contact with the belt.
IMPORTANT: In some cases, due to irregular belt wear or cupping, it may be necessary to make final adjustments independently on both sides.
- Tighten the lock nuts on the adjusting bolts to secure the blade in the correct position. Also tighten the bearing mount set screws and lock nuts.

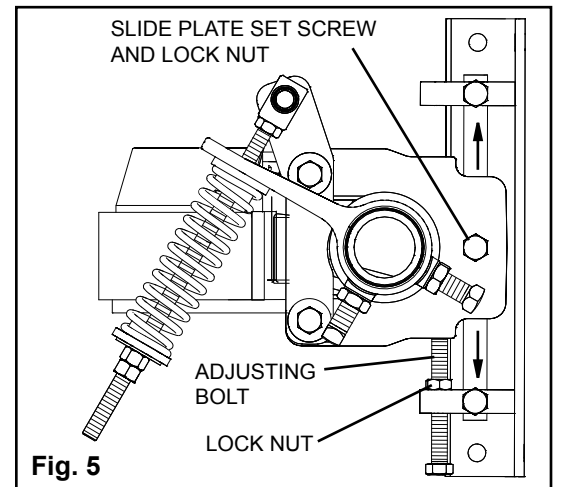

Fig. 5

STEP 6. Set the blade tension.

- Set spring length to determined length (Fig. 6).
IMPORTANT: Always be sure there is uniform contact between the blade and the belt.
- If the blade is not in full contact with the belt at the edges and the center, either raise or lower the pole position of the cleaner and reapply the tension.

SPRING LENGTH CHART

BLADE WIDTH	PURPLE SPRING	SILVER SPRING
18"	6"	N/A
24"	5 3/4"	N/A
30"	5 5/8"	N/A
36"	5 3/8"	N/A
42"	5 1/4"	N/A
48"	5	N/A
54"	4 3/4"	N/A
60"	4 5/8"	N/A
72"	N/A	5 5/8"
84"	N/A	5 3/8"

ADJUSTING NUTS
Top of washer to top of torque arm

Fig. 6

CHUTE MOUNTING ACCESS HOLE DIMENSIONS:

Belt Width	H Dimension
18" - 42" (450-1050mm)	8" (200mm)
48" - 84" (1200-2100mm)	10" (250mm)

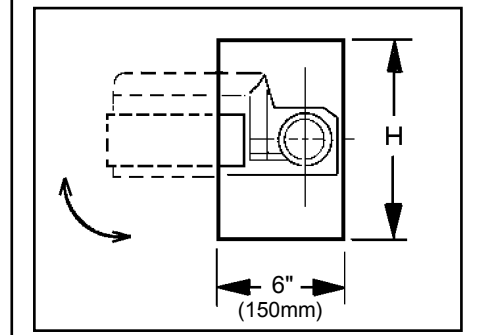

1995 Oak Industrial Dr. NE • Grand Rapids, MI 49505 U.S.A.
Telephone: (616)-459-3196 • Fax: (616)-459-4976 • E-mail: info@flexco.com • Web: www.flexco.com

Australia: 61-2-9680-3322 • China: 86-21-33528388 • England: 44-1274-600-942
Germany: 49-7428-9406-0 • Mexico: 52-55-5674-5326 • South Africa: 27-11-608-4180

©2008 Flexible Steel Lacing Company. Eliminator® and U-Type® are registered trademarks.
Patent pending. 12-08. For Reorder: X1686

