

Replacement Parts List

Eliminator® H-Type®

Precleaners

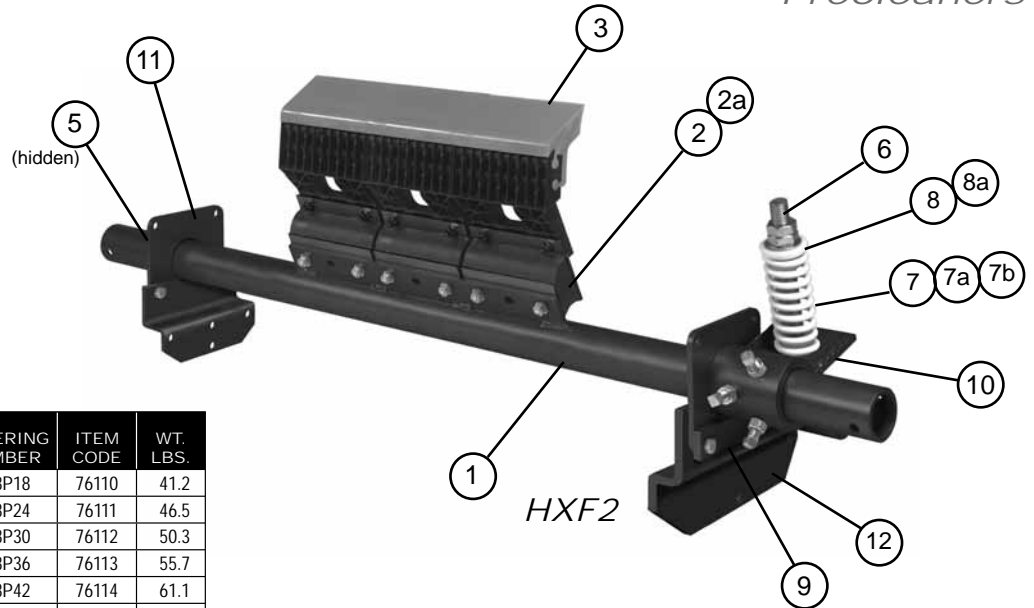

Replacement Parts

REF	DESCRIPTION	ORDERING NUMBER	ITEM CODE	WT. LBS.
1	18" (450mm) Pole	H78P18	76110	41.2
	24" (600mm) Pole	H78P24	76111	46.5
	30" (750mm) Pole	H78P30	76112	50.3
	36" (900mm) Pole	H78P36	76113	55.7
	42" (1050mm) Pole	H78P42	76114	61.1
	48" (1200mm) Pole	H78P48	76115	64.9
	54" (1350mm) Pole	H78P54	76116	70.3
	60" (1500mm) Pole	H78P60	76117	99.8
	72" (1800mm) Pole	H78P72	76118	113.0
2	H2 XF-Tip Cushion* (for S, M, L HXF2-Tips; or S - LL Susp. Arms)	HXFC2	75902	4.0
2a	H2 F-Tip Cushion* (for SS HXF2 Tips; or SS Susp. Arms)	HFC2	75901	4.0
3	HXF2-Tip Extra Small*	HXF2-SS	75979	3.0
	HXF2-Tip Small*	HXF2-S	75980	3.4
	HXF2-Tip Medium*	HXF2-M	75981	3.8
	HXF2-Tip Large*	HXF2-L	75982	4.1
3a	H V-Tip* (1 ea.)	HVT8	73042	1.0
3b	H Protected V-Tip* (1 ea.) (for vulcanized belts only)(for abusive wear)	HVPT	73631	2.7
4	H SS Suspension Arm*	HSA8SS	73047	0.5
	H S Suspension Arm*	HSA8S	73048	1.0
	H M Suspension Arm*	HSA8M	73049	1.5
	H L Suspension Arm*	HSA8L	73063	2.0
	H LL Suspension Arm*	HSA8LL	73064	2.5
5	Pole Lock Collar* (1 ea.)	MSPPL	75816	1.9
6	Pivot Arm Kit* (1 ea.)	QMTPAK	76096	4.3
7	Tension Spring - Purple (1 ea.)**	QMTS-P	75845	0.6
7a	Tension Spring - White (1 ea.)**	PSTS-W	75898	1.7
7b	Tension Spring - Silver (1 ea.)**	PSTS-S	75899	3.0
8	Bushing Kit - Purple (2 ea.) (for Item 7)	QMTBK-P	76097	0.1
8a	Bushing Kit - White (2 ea.) (for Items 7a & 7b)	QMTBK-W	76098	0.2
9	Pivot Shaft Bracket Kit* (1 ea.)	QMTSBK	76099	4.3
10	Torque Arm Kit* (1 ea.)	PSTA	75896	11.4
11	Mounting Plate Kit* (2 ea.)	MSPMPK	75811	8.3
12	Offset Bracket Kit* (1 ea.)	HOBK	76399	12.4
13	H SS Tip Shield	HSSTS	74771	0.5
-	H SS Cushion Shield	HSSCS	74772	0.6
-	QMT Spring Tensioner* - Purple (incl. 1 ea. Items 6, 7, 8, 9, & 10)	QMT-P	76074	20.4
-	QMT Spring Tensioner* - White (incl. 1 ea. Items 6, 7a, 8a, 9, & 10)	QMT-W	76075	21.8
-	QMT Spring Tensioner* - Silver (incl. 1 ea. Items 6, 7b, 8a, 9, & 10)	QMT-S	76402	23.9

*Hardware included

Note: All poles and tensioners are heavy-duty style.

Parts for old style H cleaners - See page 73.

Lead time: 1 working day

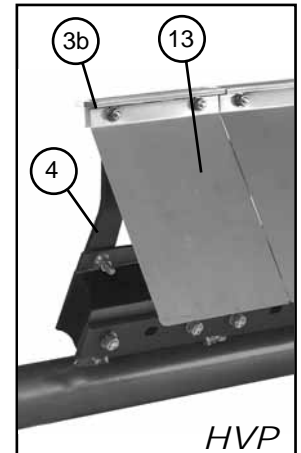
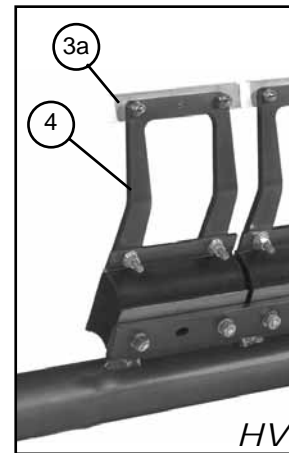

Spring Tensioner Selection Chart

CLEANER TYPE AND SIZE	76074 OMT-P	76075 OMT-W	76402 OMT-S
HXF2			
18" SS & S	X		
18" M; 24"-36"; 42"-48" SS & S; 54" SS		X	
42"-48" M & L; 54"-72" S, M, L			X
HV			
18" SS, S, M; 24"-30" SS & S	X		
24"-30" M; 36"-48", 54" S, M, L; 60" S		X	
54" LL; 60" M, L, LL; 72"			X
HVP			
18" S, M; 24"-30" S	X		
24"-30" M; 36"-48"; 54" S, M, L; 60" S		X	
54" LL; 60" M, L, LL; 72"			X

Eliminator®
BELT CLEANING SYSTEMS