

MSP PRECLEANER REPLACEMENT PARTS LIST

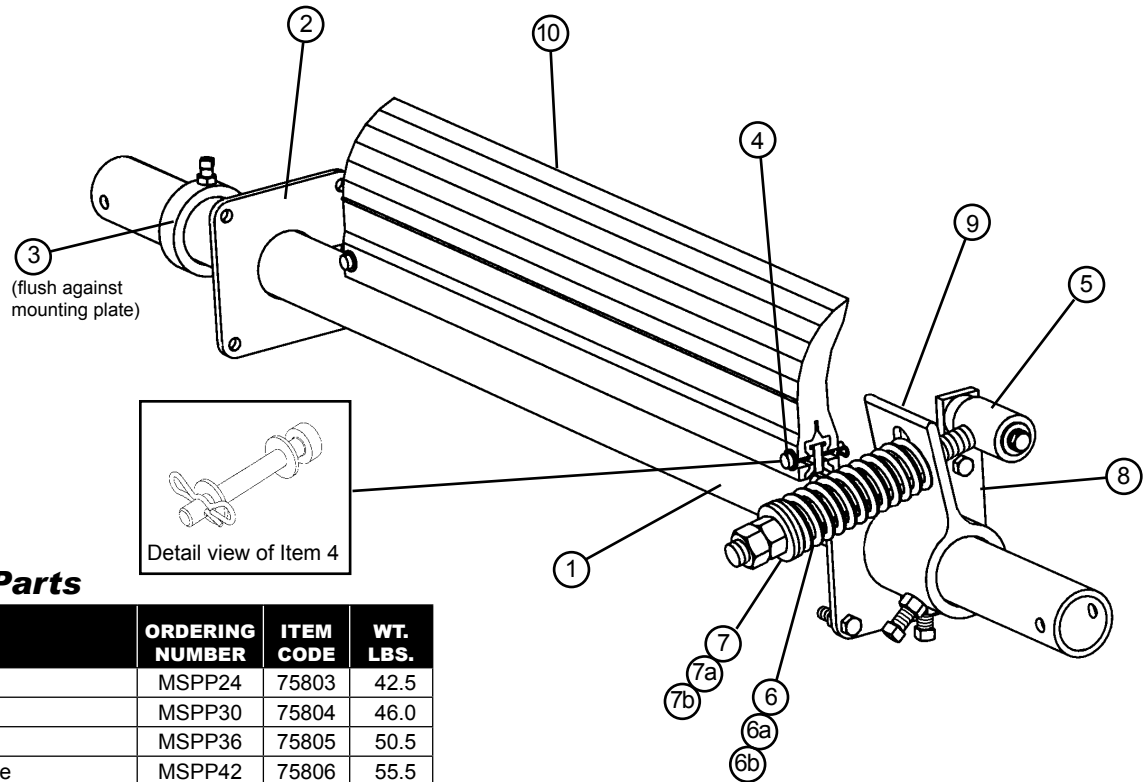

Replacement Parts

REF	DESCRIPTION	ORDERING NUMBER	ITEM CODE	WT. LBS.
1	24" (600mm) Pole	MSPP24	75803	42.5
	30" (750mm) Pole	MSPP30	75804	46.0
	36" (900mm) Pole	MSPP36	75805	50.5
	42" (1050mm) Pole	MSPP42	75806	55.5
	48" (1200mm) Pole	MSPP48	75807	60.0
	54" (1350mm) Pole	MSPP54	75808	64.0
	60" (1500mm) Pole	MSPP60	75809	67.0
	72" (1800mm) Pole	MSPP72	75810	76.0
	84" (2100mm) Pole	MSPP84	76807	88.6
2	Mounting Plate Kit* (2 ea.)	MSPMPK	75811	8.3
3	Pole Lock* (1 ea.)	MSPPL	75816	1.9
4	Blade Pin Kit* (1 ea.)	MSPBPK	75831	0.1
5	Pivot Arm Kit* (1 ea.)	QMTPAK	76096	4.3
6	Tension Spring - Purple (1 ea.) for blades 16" - 28" (400 - 700mm)	QMTS-P	75845	0.6
6a	Tension Spring - White (1 ea.) for blades 34" - 70" (850 - 1750mm)	PSTS-W	75898	1.7
6b	Tension Spring - Gold (1 ea.) for blades 76" - 82" (1900 - 2050mm)	QMTS-G	76484	2.5
7	Bushing Kit - Purple (2 ea.)	QMTBK-P	76097	0.1
7a	Bushing Kit - White (2 ea.)	QMTBK-W	76098	0.2
7b	Bushing Kit - Gold (2 ea.)	QMTBK-G	76540	0.3
8	Pivot Shaft Bracket Kit* (1 ea.)	QMTPSBK	76099	4.3
9	Torsion Arm Kit* (1 ea.)	PSTA	75896	11.4
-	QMT Spring Tensioner* - Purple (incl. 1 ea. Items 5, 6, 7, 8, & 9) for blades 16" - 28" (400 - 700mm)	QMT-P	76074	20.4
-	QMT Spring Tensioner* - White (incl. 1 ea. Items 5, 6a, 7a, 8, & 9) for blades 34" - 70" (850 - 1750mm)	QMT-W	76075	21.8
-	QMT Spring Tensioner* - Gold (incl. 1 ea. Items 5, 6b, 7b, 8, & 9) for blades 76" - 82" (1900 - 2050mm)	QMT-G	76483	23.2

*Hardware Included

Lead Time: 1 working day

Replacement ConShear™ Blades

REF	BLADE WIDTH		ORDERING NUMBER	ITEM CODE	WT. LBS.
	in.	mm			
10	10	250	CRB10	75628	4.6
	16	400	CRB16	75629	7.3
	22	550	CRB22	75630	10.1
	28	700	CRB28	75631	12.8
	34	850	CRB34	75632	15.5
	40	1000	CRB40	75633	18.3
	46	1150	CRB46	75634	21.0
	52	1300	CRB52	75635	23.8
	58	1450	CRB58	75636	26.5
	64	1600	CRB64	75775	29.2
	70	1750	CRB70	75773	32.0
	76	1900	CRB76	76940	34.7
	82	2050	CRB82	76941	37.5

Order blade width for your belt width's material path: Belt Width Minus 2", Belt Width Minus 8" or Belt Width Minus 14".
Lead Time: 1 working day

Spring Tensioner Selection Chart

CLEANER BLADE WIDTH	76074 QMT-P	76075 QMT-W	76483 QMT-G
ConShear 16" - 28" (400 - 700mm)	X		
ConShear 34" - 70" (850 - 1750mm)		X	
ConShear 76" - 82" (1900 - 2050mm)			X

1995 Oak Industrial Dr. NE • Grand Rapids, MI 49505 U.S.A.
Telephone: (616)-459-3196 • Fax: (616)-459-4976 • E-mail: info@flexco.com • Web: www.flexco.com

Australia: 61-2-9680-3322 • China: 86-21-33528388 • England: 44-1274-600-942
Germany: 49-7428-9406-0 • Mexico: 52-55-5674-5326 • South Africa: 27-11-608-4180

©2008 Flexible Steel Lacing Company. Mineline® is a registered trademark.
U.S. Patent No. D482,508S. 08/08. For Reorder: X1325

